

PROTECTING ARMATURES AND GAUGE SLIDES

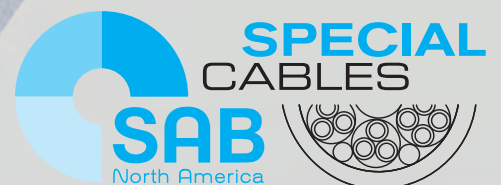

www.sabcable.com
866-722-2974 ■ info@sabcable.com



SAB North America

About Us

SAB North America is a focused supplier for the automation, aerospace, medical, high temperature, and robotics industries, providing cable and thermocouple solutions that meet, exceed, and set new standards in the flexible cable market. In addition to flexible cable products, we offer an extensive inventory of high-quality cable accessories, including cord grips, grounding glands and other accessories that complement our flexible control and automation cables.

Whatever the need may be, look to SAB North America for Special Cables that can, for example, help minimize maintenance costs and increase productivity, reduce downtime, and solve specific problems. Here is a small sample of some of the challenges that Special Cables from SAB North America can help address:

- Hybrid designs for multiple functions
- Harsh environments
- Difficult applications
- Industry-specific requirements



SAB thermometers are constructed with protecting tubes. These protecting armatures protect the sensitive gauge slide against mechanical and chemical stress and the connection clamps against dirt and humidity. It consists of a protecting tube and a connection head. As a leading manufacturer of thermocouples, we are able to design and to produce a special thermometer that meet your special requirements.

SAB's level of speed and service as a supplier is unmatched. SAB lives up to its name in not only flexible cable but also flexible manufacturing.



SAB Advantage...We make it Easy

- Engineering & technical assistance
- Cut to length with no cut charges
- Prepaid freight within US for orders over \$2,500
- Specialty cable designs (1500 ft minimum)
- No minimum on orders from stock
- Free drop shipments (no surcharges)
- 24-hour shipments from stock
- Cord Grips for securing and grounding cables

■ Production possibilities	4
----------------------------------	---

Protecting armatures for gauge slides

■ T401 thermometer without additional protecting tube form MK	6
■ T402 thermometer with 1 transmitter in the cap without additional protecting tube form MK	6
■ T403 thermometer with 1 transmitter without additional protecting tube form MK	7
■ T404 thermometer with 2 transmitters without additional protecting tube form MK	7
■ T411 / T413 immersion protecting armatures for gauge slides Ø 3 mm / Ø 8 mm	8
■ T421 screw-in protecting armatures for gauge slides Ø 6 mm	9
■ T425 / T427 flange protecting armature for gauge slides Ø 3 mm / Ø 6 mm	10
■ T434 / T435 plug-in protecting armatures for gauge slides Ø 3 mm / Ø 6 mm	11
■ T433 / T445 screw-in protecting armatures for gauge slides Ø 3 mm / Ø 6 mm	12
■ T450 / T451 weld-in protecting armatures for gauge slides Ø 3 mm / Ø 6 mm	13

Gauge slides for resistance thermometers

■ T713 RTD (mineral insulated) gauge slide	14
■ T720 RTD (mineral insulated) gauge slide with 1 transmitter	15
■ T721 RTD (mineral insulated) gauge slide with 1 transmitter and with connection for the second transmitter	15

Gauge slides for thermocouples

■ T752 MTC gauge slide with connection socket	16
■ T760 MTC gauge slide with 1 transmitter	16
■ T761 MTC gauge slide with 1 transmitter and with connection for the second transmitter	16

■ Accessories	17-20
---------------------	-------

General

■ Introduction	21
■ General instructions for temperature measurement	22
■ Comparison Thermocouples / resistance thermometers	23
■ Response time mineral insulated thermocouples / resistance thermometers	24
■ Materials and application fields	25
■ Charge diagram of protecting tubes	26-27
■ Technical description of gauge slides	28
■ Technical description of transmitters	29
■ HALAR®-coating	30
■ Calibration / test certificates	31

Thermoelements

■ Basics thermocouples / connection cables	32
■ Basic values of thermoelectric voltage in mV	33
■ Ø-Tolerances of mineral insulated thermocouples	34
■ Characteristics of thermocouples	35
■ Color code and temperature range	36

Resistance thermometers

■ Basics of resistance thermometers	37
■ Technical description of mineral insulated resistance thermometers	37
■ Basic values of RTDs	38
■ Terminal connection / color code connection socket	39
■ Connection of resistance thermometers	40
■ Inner wires of resistance thermometers	41

Production possibilities

Flexible cables and wires “Made in Germany”

As a leading manufacturer we develop and produce cables for industrial purposes.

Our wide range of materials offer a lot of possibilities for your individual product requirement.

The following survey shows an extract of our production possibilities:

Conductor Materials:

- ✓ bare copper
- ✓ tinned copper
- ✓ silver plated copper
- ✓ nickel plated copper
- ✓ nickel
- ✓ nickel pure
- ✓ compensating cable alloys

Insulation and Jacketing Materials:

- ✓ PVC
- ✓ Polyethylene
- ✓ Polypropylene
- ✓ Polyurethane
- ✓ TPE
- ✓ SABIX® (zero halogen)
- ✓ Besilen® - Silicone
- ✓ FEP, ETFE, PFA, PTFE
- ✓ PI foil
- ✓ Fiberglass

Temperature Ranges:

- Thermoplastic Elastomers
- ✓ -50°C up to +145°C
- SABIX®
- ✓ -50°C up to +220°C
- Besilen® - Silicone
- ✓ -40°C up to +220°C
- FEP, ETFE, PFA
- ✓ -90°C up to +260°C
- Fiberglass
- ✓ up to +600°C

Conductors:

- ✓ cross sections 0.055 - 300 mm²
- ✓ unshielded and shielded over 100 conductors

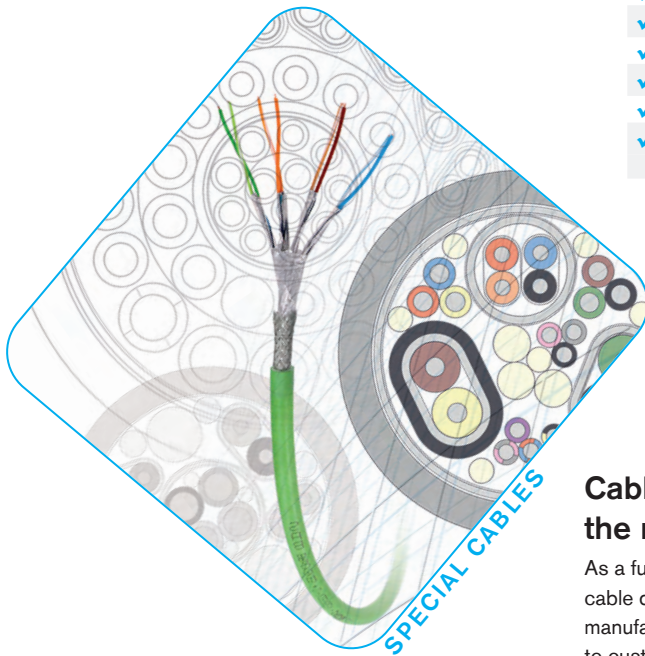

Cable assemblies directly from the manufacturer SAB:

As a full service partner, we are able to offer cable design and production as well as the manufacturing of cable assemblies according to customer's request. Please trust on our experience for decades in the treatment of cables and connectors.

- ✓ cable assemblies according to customer's demands
- ✓ complete cable assemblies
- ✓ UL certified assemblies
- ✓ helix cables
- ✓ HV measuring assemblies

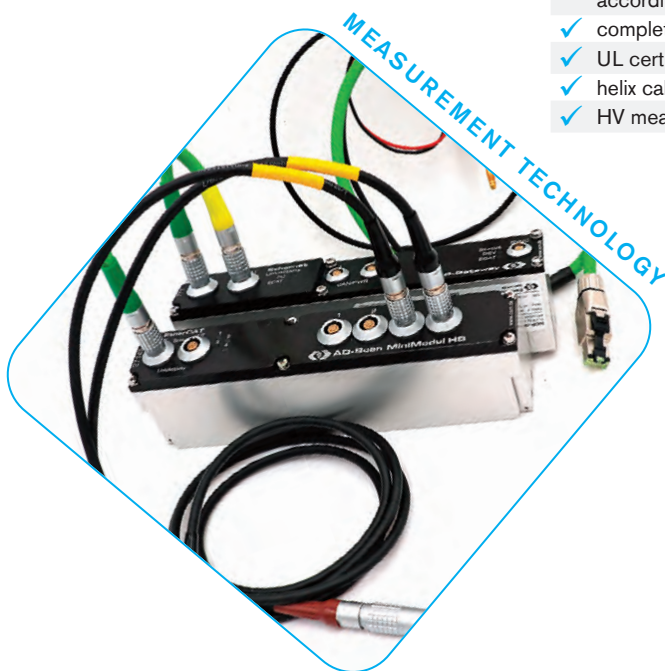

Measuring technology for industrial applications

Manufacturer of temperature sensors for industrial applications with 75 years of experience!

- ✓ mineral insulated thermocouples
- ✓ mineral insulated resistance thermometers
- ✓ temperature sensors
- ✓ mobile high voltage measuring technology
- ✓ temperature sensors for vehicle testing

OUR TEMPERATURE MEASUREMENT

AT A GLANCE

WITH US YOU GET **TEMPERATURE MEASUREMENT**
AND **ACCESSORIES** FOR A WIDE VARIETY OF REQUIREMENTS AND INDUSTRIES.

Protecting armatures and gauge slides

- Immersion protecting armatures
- Screwed protecting armatures
- Welding protecting armatures, etc.

Temperature measurement in test vehicles

- Thermo 8-plug connector
- Dipstick thermocouples
- Thermocouples for cooling water tube applications, etc.

Mineral insulated thermocouples/ Mineral insulated resistance thermometers

- with fixed connecting cable
- with bare connection ends
- with thermo-plug/miniature plug, etc.

Temperature measurement in plastics processing industry/Hot runner technique

- Hot runner mineral insulated thermocouples
- Plug-in thermocouples
- Molten mass thermocouples, etc.

Probe with stainless steel sleeve

- available as thermocouple
- available as resistance thermometer

Compensating and extension cables

- Compensating and extension cables for thermocouples
- Connection cables for resistance thermometers, etc.

Accessories

- Clamping screw connections
- Flanges
- Screw sockets
- Connection heads
- Welding protecting tubes
- Transmitters
- Thermo-plugs/sockets
- Screw-in nipples
- Miniature plugs/sockets

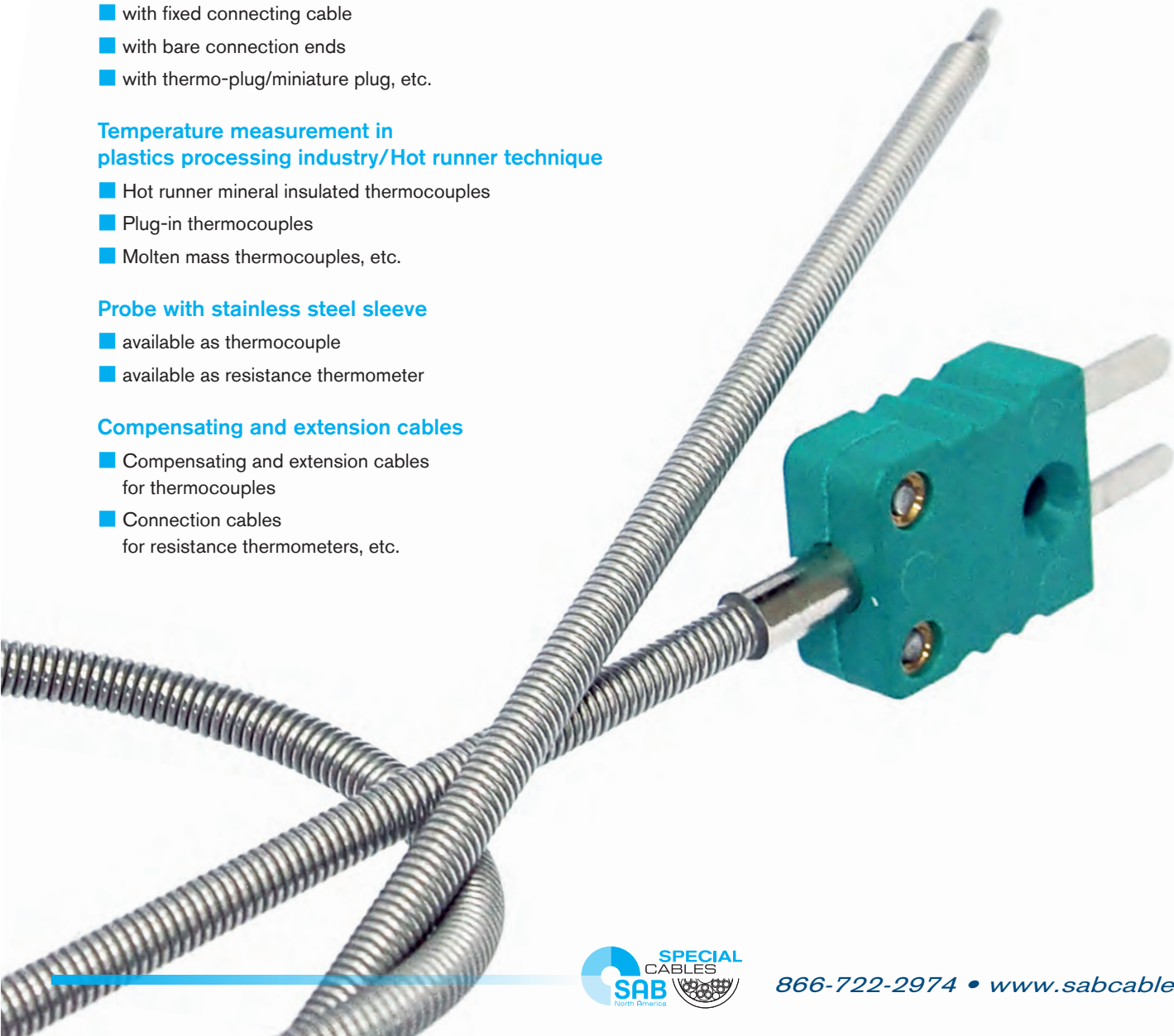

PROTECTING ARMATURES FOR GAUGE SLIDES

T401 Thermometer without additional protecting tube form MK

T402 Thermometer with 1 transmitter in the cap without additional protecting tube form MK

T401

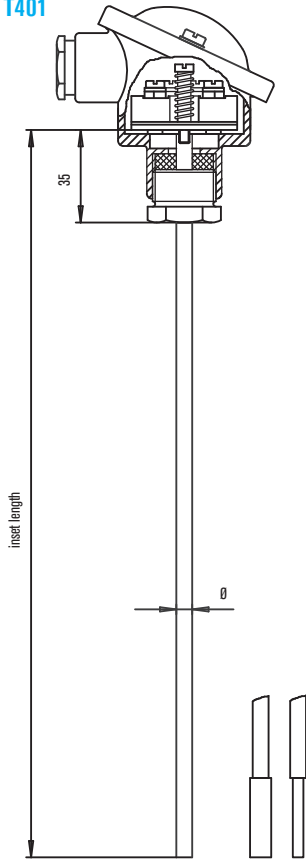

CONNECTION HEAD:

- B (KE 122)
- DAN-S (KE 066)
- other connection head: _____
- DAN-Z (KE 064)
- BNK (KK 029)

Ø JACKET / MEASURING TIP:

- 3.0/3.0 mm
- 6.0/8.0 mm
- 4.5/4.5 mm
- 6.0/4.0 mm
- 6.0/6.0 mm
- 8.0/8.0 mm
- other Ø: _____

INSET LENGTH:

- 255 mm
- 340 mm
- 435 mm
- 655 mm
- 1275 mm
- 2025 mm
- 275 mm
- 375 mm
- 525 mm
- 735 mm
- 1425 mm
- 2425 mm
- 290 mm
- 405 mm
- 555 mm
- 825 mm
- 1625 mm
- 3025 mm
- 315 mm
- 430 mm
- 580 mm
- 1025 mm
- 1825 mm
- other length: _____

ADDITIONAL INFORMATION ABOUT THE THERMOCOUPLE OR RESISTANCE THERMOMETER PLEASE SPECIFY HERE:

T402

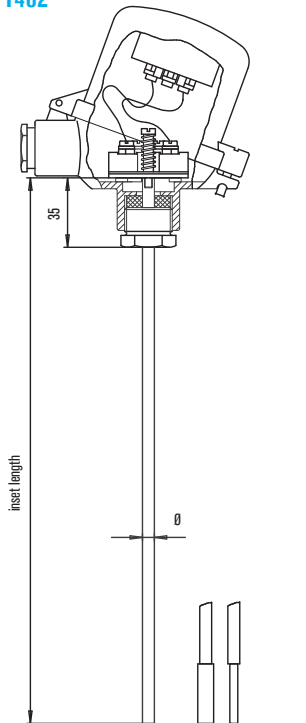

CONNECTION HEAD:

- DAN-WZ (KE 202)
- DAN-WS (KE 204)
- other connection head: _____

Ø JACKET / MEASURING TIP:

- 3.0/3.0 mm
- 6.0/8.0 mm
- 4.5/4.5 mm
- 6.0/4.0 mm
- 6.0/6.0 mm
- 8.0/8.0 mm
- other Ø: _____

INSET LENGTH:

- 255 mm
- 340 mm
- 435 mm
- 655 mm
- 1275 mm
- 2025 mm
- 275 mm
- 375 mm
- 525 mm
- 735 mm
- 1425 mm
- 2425 mm
- 290 mm
- 405 mm
- 555 mm
- 825 mm
- 1625 mm
- 3025 mm
- 315 mm
- 430 mm
- 580 mm
- 1025 mm
- 1825 mm
- other length: _____

ADDITIONAL INFORMATION ABOUT THE THERMOCOUPLE OR RESISTANCE THERMOMETER PLEASE SPECIFY HERE:

PROTECTING ARMATURES FOR GAUGE SLIDES

T403 Thermometer with 1 transmitter without additional protecting tube form MK

T404 Thermometer with 2 transmitters without additional protecting tube form MK

T403

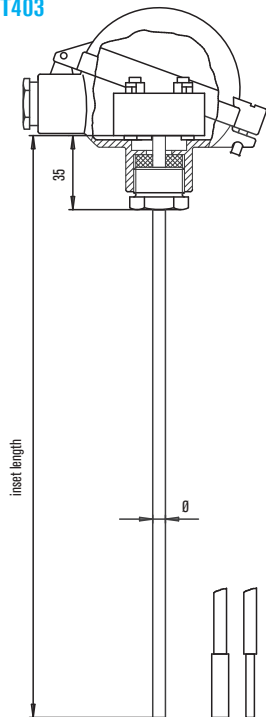

CONNECTION HEAD:

- DAN-Z (KE 064) DAN-S (KE 066)
- other connection head: _____

Ø JACKET / MEASURING TIP:

- 3.0/3.0 mm 6.0/8.0 mm
- 4.5/4.5 mm 6.0/4.0 mm
- 6.0/6.0 mm 8.0/8.0 mm other Ø: _____

INSET LENGTH:

- 255 mm 340 mm 435 mm 655 mm 1275 mm 2025 mm
- 275 mm 375 mm 525 mm 735 mm 1425 mm 2425 mm
- 290 mm 405 mm 555 mm 825 mm 1625 mm 3025 mm
- 315 mm 430 mm 580 mm 1025 mm 1825 mm
- other length: _____

ADDITIONAL INFORMATION ABOUT THE THERMOCOUPLE OR RESISTANCE THERMOMETER PLEASE SPECIFY HERE:

T404

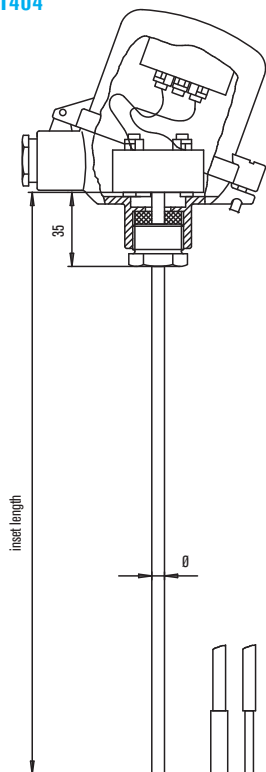

CONNECTION HEAD:

- DAN-WZ (KE 202) DAN-WS (KE 204)
- other connection head: _____

Ø JACKET / MEASURING TIP:

- 3.0/3.0 mm 6.0/8.0 mm
- 4.5/4.5 mm 6.0/4.0 mm
- 6.0/6.0 mm 8.0/8.0 mm other length: _____

INSET LENGTH:

- 255 mm 340 mm 435 mm 655 mm 1275 mm 2025 mm
- 275 mm 375 mm 525 mm 735 mm 1425 mm 2425 mm
- 290 mm 405 mm 555 mm 825 mm 1625 mm 3025 mm
- 315 mm 430 mm 580 mm 1025 mm 1825 mm
- other length: _____

ADDITIONAL INFORMATION ABOUT THE THERMOCOUPLE OR RESISTANCE THERMOMETER PLEASE SPECIFY HERE:

PROTECTING ARMATURES FOR GAUGE SLIDES

T411 / T413

Immersion protecting armatures for gauge slides \varnothing 3 mm / \varnothing 8 mm

T413 / FOR GAUGE SLIDE \varnothing 3 mm

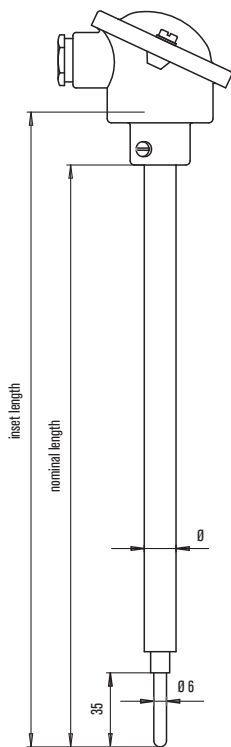

PROTECTING TUBE FORM AS TAPERED MEASURING TIP (QUICK RESPONSE TIME):

- 1.0305 \varnothing 15 x 2 mm
- 1.4571 \varnothing 15 x 2 mm
- 1.4762 \varnothing 15 x 2 mm
- 1.4841 \varnothing 15 x 2 mm

GAUGE SLIDE:

- without gauge slide
- with gauge slide: _____

FIXING:

- without
- with flange
- with screw socket G1/2 A
- with screw socket G3/4 A
- with screw socket G1 A
- with screwed plug G1/2 A

CONNECTION HEAD:

- B (KE 021)
- DAN-WS (KE 203)
- other connection head: _____
- DAN-WZ (KE 201)
- DAN-S (KE 065)
- DAN-Z (KE 063)
- BNK (KK 028)

NOMINAL LENGTH / INSET LENGTH:

- 500/525 mm
- 710/735 mm
- 1000/1025 mm
- 1400/1425 mm
- 2000/2025 mm
- 180/205 mm
- 250/275 mm
- 355/380 mm
- other length: _____

ADDITIONAL INFORMATION:

T411 / FOR GAUGE SLIDE \varnothing 8 mm

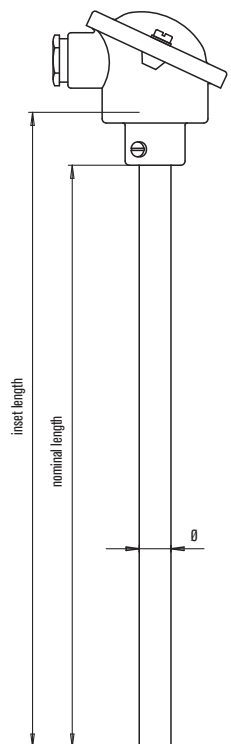

PROTECTING TUBE FORM ACC. TO DIN 43763:

- 1.0305 \varnothing 15 x 3 mm
- 1.4571 \varnothing 15 x 2 mm, tip 15 x 3 mm
- 1.4762 \varnothing 15 x 2 mm
- 1.4841 \varnothing 15 x 2 mm

GAUGE SLIDE:

- without gauge slide
- with gauge slide: _____

FIXING:

- without
- with stop flange
- with screw socket G1/2 A
- with screw socket G3/4 A
- with screw socket G1 A
- with screwed plug G1/2 A

CONNECTION HEAD:

- B (KE 021)
- DAN-WS (KE 203)
- other connection head: _____
- DAN-WZ (KE 201)
- DAN-S (KE 065)
- DAN-Z (KE 063)
- BNK (KK 028)

NOMINAL LENGTH / INSET LENGTH:

- 500/525 mm
- 710/735 mm
- 1000/1025 mm
- 1400/1425 mm
- 2000/2025 mm
- 180/205 mm
- 250/275 mm
- 355/380 mm
- other length: _____

ADDITIONAL INFORMATION:

PROTECTING ARMATURES FOR GAUGE SLIDES

T421

Screw-in protecting armatures for gauge slides \varnothing 6 mm

T421 / FOR GAUGE SLIDE \varnothing 6 mm

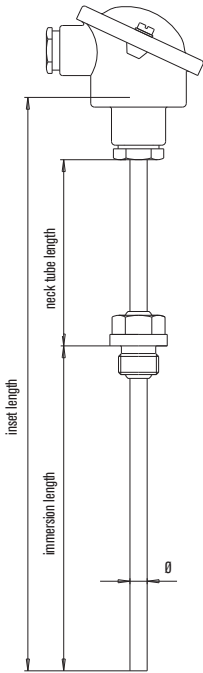

PROTECTING TUBE FORM B:

- 1.3050 \varnothing 11 x 2 mm
- 1.4571 \varnothing 11 x 2 mm
- 1.4571 \varnothing 9 x 1 mm
- 1.7335 \varnothing 11 x 2 mm

GAUGE SLIDE:

- without gauge slide
- with gauge slide: _____

SCREWED THREAD:

- G 1/2 A
- G 3/4 A
- G 1 A
- without
- other thread: _____

CONNECTION HEAD:

- B (KE 122)
- DAN-WZ (KE 202)
- without
- DAN-Z (KE 064)
- DAN-WS (KE 204)
- other connection head: _____
- DAN-S (KE 066)
- BNK (KK 029)

INSET / NECK TUBE / IMMERSION LENGTH:

- 100/120/255 mm
- 400/120/555 mm
- 670/120/825 mm
- 160/120/315 mm
- 500/120/655 mm
- 870/120/1025 mm
- 250/120/405 mm
- 580/120/735 mm
- other length: _____

ADDITIONAL INFORMATION:

PROTECTING ARMATURES FOR GAUGE SLIDES

T425 / T427

Flange protecting armature for gauge slides \varnothing 3 mm / \varnothing 6 mm

T427 / FOR GAUGE SLIDE \varnothing 3 mm

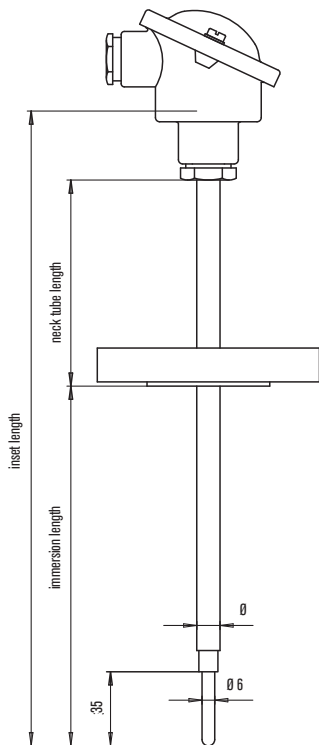

PROTECTING TUBE FORM FS WITH TAPERED MEASURING TIP (QUICK RESPONSE TIME):

- 1.4571 \varnothing 11 x 2 mm
- 1.4571 \varnothing 11 x 2 mm - HALAR® - coating

GAUGE SLIDE:

- without gauge slide
- with gauge slide: _____

FLANGE:

- DN 20 PN 40 DIN EN 1092-1
- DN 40 PN 40 DIN EN 1092-1
- DN 25 PN 40 DIN EN 1092-1
- DN 50 PN 40 DIN EN 1092-1

CONNECTION HEAD:

- B (KE 122)
- DAN-Z (KE 064)
- DAN-S (KE 066)
- DAN-WZ (KE 202)
- DAN-WS (KE 204)
- BNK (KK 029)
- without
- other connection head: _____

INSET / NECK TUBE / IMMERSION LENGTH:

- 100/120/255 mm
- 160/120/315 mm
- 250/120/405 mm
- 400/120/555 mm
- other length: _____

ADDITIONAL INFORMATION:

T425 / FOR GAUGE SLIDE \varnothing 6 mm

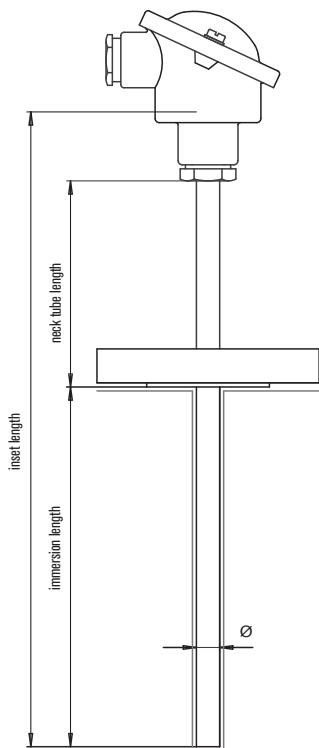

PROTECTING TUBE FORM FS WITH TAPERED MEASURING TIP (QUICK RESPONSE TIME):

- 1.4571 \varnothing 11 x 2 mm
- 1.4571 \varnothing 11 x 2 mm - HALAR® - coating

GAUGE SLIDE:

- without gauge slide
- with gauge slide: _____

FLANGE:

- DN 20 PN 40 DIN EN 1092-1
- DN 40 PN 40 DIN EN 1092-1
- DN 25 PN 40 DIN EN 1092-1
- DN 50 PN 40 DIN EN 1092-1

CONNECTION HEAD:

- B (KE 122)
- DAN-Z (KE 064)
- DAN-S (KE 066)
- DAN-WZ (KE 202)
- DAN-WS (KE 204)
- BNK (KK 029)
- without
- other connection head: _____

INSET / NECK TUBE / IMMERSION LENGTH:

- 100/120/255 mm
- 160/120/315 mm
- 250/120/405 mm
- 400/120/555 mm
- other length: _____

ADDITIONAL INFORMATION:

PROTECTING ARMATURES FOR GAUGE SLIDES

T434 / T435

Plug-in protecting armatures for gauge slides \varnothing 3 mm / \varnothing 6 mm

T434 / FOR GAUGE SLIDE \varnothing 3 mm

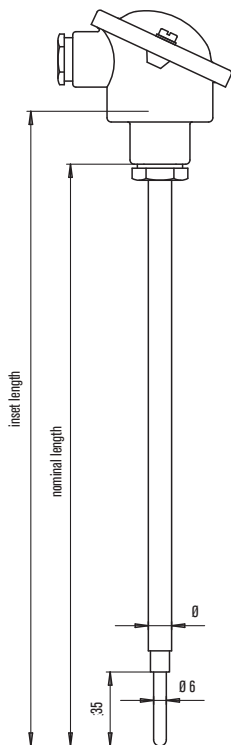

PROTECTING TUBE FORM VKS WITH TAPERED MEASURING TIP:

- 1.4571 \varnothing 12 x 2.5 mm

GAUGE SLIDE:

- without gauge slide with gauge slide: _____

SCREWED THREAD:

- G 1/2 A - clamping screw connection without
 1/2" NPT - clamping screw connection

CONNECTION HEAD:

- B (KE 122) DAN-WZ (KE 202) without
 DAN-Z (KE 064) DAN-WS (KE 204) other connection head: _____
 DAN-S (KE 066) BNK (KK 029)

NOMINAL / INSET LENGTH:

- 250/275 mm 380/405 mm 530/555 mm
 290/315 mm 410/435 mm 630/655 mm
 350/375 mm 500/525 mm other length: _____

ADDITIONAL INFORMATION:

T435 / FOR GAUGE SLIDE \varnothing 6 mm

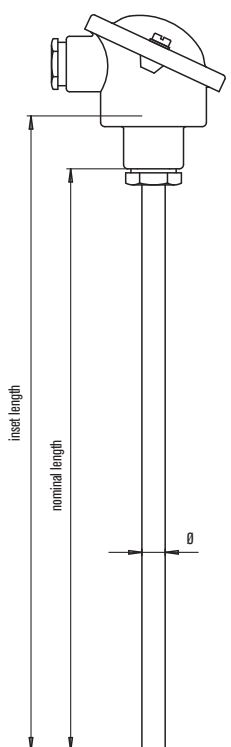

PROTECTING TUBE FORM VK:

- 1.4571 \varnothing 12 x 2.5 mm 1.4571 \varnothing 10 x 1.5 mm
 1.4571 \varnothing 10 x 2 mm 1.4571 \varnothing 8 x 0.75 mm

GAUGE SLIDE:

- without gauge slide with gauge slide: _____

SCREWED THREAD:

- without G 1/2 A - clamping screw connection
 G 1/4 A - clamping screw connection 1/2" NPT - clamping screw connection

CONNECTION HEAD:

- B (KE 122) DAN-WZ (KE 202) without
 DAN-Z (KE 064) DAN-WS (KE 204) other connection head: _____
 DAN-S (KE 066) BNK (KK 029)

NOMINAL / INSET LENGTH:

- 250/275 mm 380/405 mm 530/555 mm
 290/315 mm 410/435 mm 630/655 mm
 350/375 mm 500/525 mm other length: _____

ADDITIONAL INFORMATION:

PROTECTING ARMATURES FOR GAUGE SLIDES

T433 / T445

Screw-in protecting armatures for gauge slides \varnothing 3 mm / \varnothing 6 mm

T433 / FOR GAUGE SLIDE \varnothing 3 mm

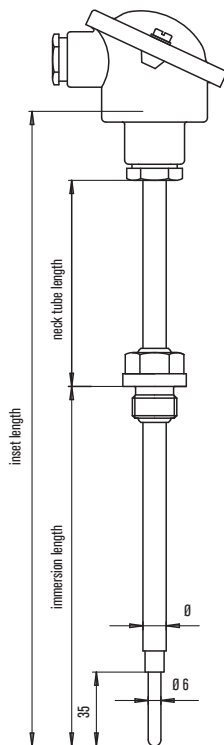

PROTECTING TUBE FORM BS WITH TAPERED MEASURING TIP:

- 1.4571 \varnothing 11 x 2 mm

GAUGE SLIDE:

- without gauge slide with gauge slide: _____

SCREWED THREAD:

- G 1/2 A G 3/4 A G 1 A
 M 20 x 1.5 without other thread: _____

CONNECTION HEAD:

- B (KE 122) DAN-WZ (KE 202) without
 DAN-Z (KE 064) DAN-WS (KE 204) other connection head:
 DAN-S (KE 066) BNK (KK 029) _____

IMMERSION / NECK TUBE / INSET LENGTH:

- 100/120/255 mm 400/120/555 mm 670/120/825 mm
 160/120/315 mm 500/120/655 mm 870/120/1025 mm
 250/120/405 mm 580/120/735 mm other length: _____

ADDITIONAL INFORMATION:

T445 / FOR GAUGE SLIDE \varnothing 6 mm

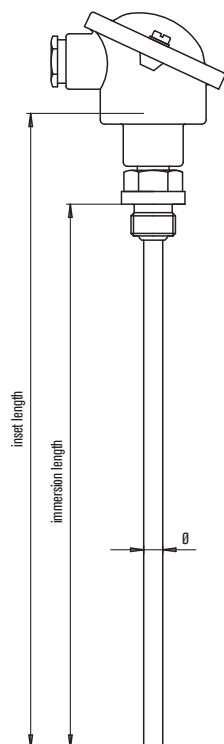

PROTECTING TUBE FORM BO WITHOUT NECK TUBE:

- 1.4571 \varnothing 9 x 1 mm 1.4571 \varnothing 11 x 2 mm
 1.4571 \varnothing 8 x 0.9 mm 1.4571 \varnothing 12 x 2.5 mm

GAUGE SLIDE:

- without gauge slide with gauge slide: _____

SCREWED THREAD:

- G 1/2 A G 3/4 A G 1 A
 M 20 x 1.5 without other thread: _____

CONNECTION HEAD:

- B (KE 021) DAN-WZ (KE 201) without
 DAN-Z (KE 063) DAN-WS (KE 203) other connection head:
 DAN-S (KE 065) BNK (KK 028) _____

IMMERSION / INSET LENGTH:

- 100/145 mm 250/295 mm
 160/205 mm 400/445 mm other length: _____

ADDITIONAL INFORMATION:

PROTECTING ARMATURES FOR GAUGE SLIDES

T450 / T451

Weld-in protecting armatures for gauge slides \varnothing 3 mm / \varnothing 6 mm

T451 / GAUGE SLIDE \varnothing 3 mm

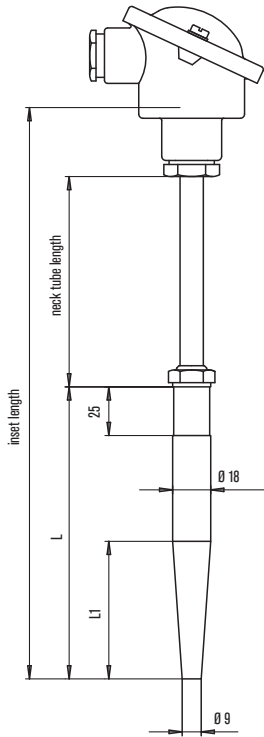

PROTECTING TUBE FORM DS (QUICK RESPONSE TIME):

- without form D 4S form D 5S

PROTECTING TUBE MATERIAL:

- 1.7335 1.7380 1.4571 1.5415 1.4961
 without protecting tube (welding sleeve)

GAUGE SLIDE:

- without gauge slide with gauge slide: _____

CONNECTION HEAD:

- B (KE 122) DAN-WZ (KE 202) without
 DAN-Z (KE 064) DAN-WS (KE 204) other connection head: _____
 DAN-S (KE 066) BNK (KK 029)

NECK TUBE LENGTH:

- 140 mm

ADDITIONAL INFORMATION:

T450 / FOR GAUGE SLIDE \varnothing 6 mm

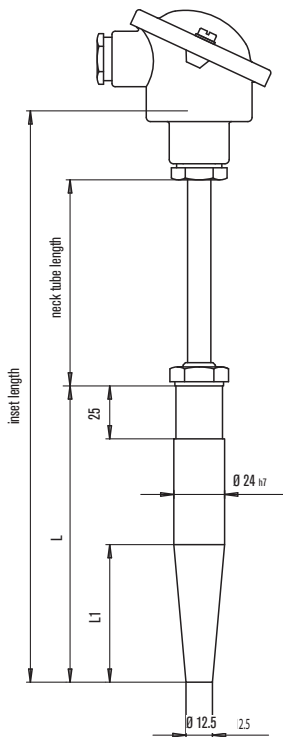

PROTECTING TUBE FORM D ACC. TO DIN 43763:

- without form D1 form D2 form D4 form D5

PROTECTING TUBE MATERIAL:

- 1.7335 1.7380 1.4571 1.5415 1.4961
 without protecting tube (welding sleeve)

GAUGE SLIDE:

- without gauge slide with gauge slide: _____

CONNECTION HEAD:

- B (KE 122) DAN-WZ (KE 202) without
 DAN-Z (KE 064) DAN-WS (KE 204) other connection head: _____
 DAN-S (KE 066) BNK (KK 029)

NECK TUBE LENGTH:

- 140 mm

ADDITIONAL INFORMATION:

GAUGE SLIDES FOR RESISTANCE THERMOMETERS

T713

RTD (mineral insulated) gauge slide

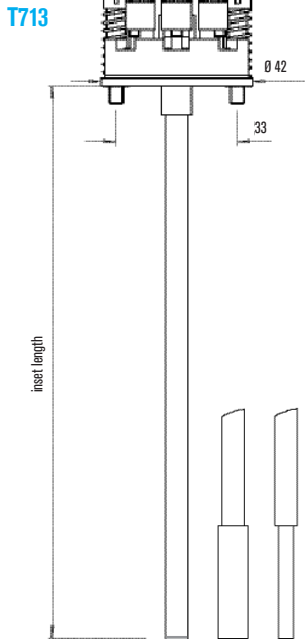

RTD:

- 1 x Pt 100 class B
- 2 x Pt 100 class B
- 1 x Pt 100 class A
- 2 x Pt 100 class A

CONNECTION TYPE OF INNER WIRES:

- 2 – wire circuit
- 3 – wire circuit
- 4 – wire circuit

Ø JACKET / MEASURING TIP / MATERIAL NO.:

- 3.0/3.0/1.4541
- 4.5/4.5/1.4541
- 6.0/6.0/1.4541
- 6.0/4.0/1.4541
- 6.0/8.0/1.4541

MEASURING TEMPERATURE RANGE:

- 50 ... +400°C
- 50 ... +600°C
- 200 ... +600°C

INSET LENGTH:

- 145 mm
- 205 mm
- 255 mm
- 275 mm
- 290 mm
- 315 mm
- 340 mm
- 375 mm
- 405 mm
- 430 mm
- 435 mm
- 455 mm
- 525 mm
- 580 mm
- 655 mm
- 735 mm
- 825 mm
- 1025 mm
- 1275 mm
- 1425 mm
- 1625 mm
- 1825 mm
- 2025 mm
- other length: _____

GAUGE SLIDES FOR RESISTANCE THERMOMETERS

T720 RTD (mineral insulated) gauge slides with 1 transmitter

T721 RTD (mineral insulated) gauge slides with 1 transmitter and with connection for the second transmitter

T720

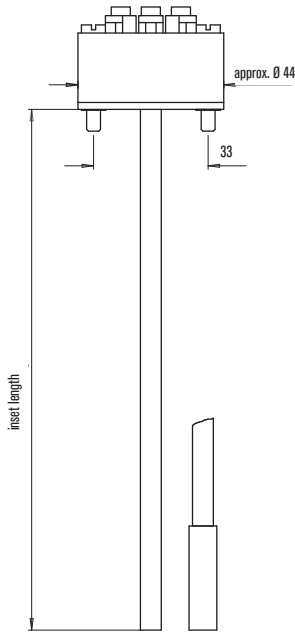

RTD:

- 1 x Pt 100 class B (T720) 2 x Pt 100 class B (T721)
- 1 x Pt 100 class A (T720) 2 x Pt 100 class A (T721)

CONNECTION TYPE OF INNER WIRES:

- 2 – wire circuit (T720 + T721)
- 3 – wire circuit (T720 + T721)
- 4 – wire circuit (only T720)

Ø JACKET / MEASURING TIP / MATERIAL NO.:

- 3.0/3.0/1.4541 6.0/6.0/1.4541
- 4.5/4.5/1.4541 6.0/8.0/1.4541

T721

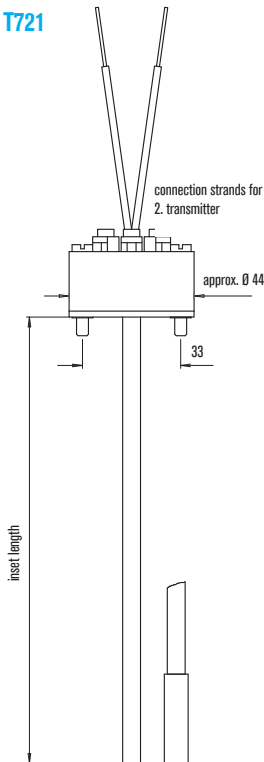

MEASURING TEMPERATURE RANGE:

- 50 ... +400°C
- 50 ... +600°C

INSET LENGTH:

- | | | |
|---------------------------------|---------------------------------|--|
| <input type="checkbox"/> 145 mm | <input type="checkbox"/> 405 mm | <input type="checkbox"/> 825 mm |
| <input type="checkbox"/> 205 mm | <input type="checkbox"/> 430 mm | <input type="checkbox"/> 1025 mm |
| <input type="checkbox"/> 255 mm | <input type="checkbox"/> 435 mm | <input type="checkbox"/> 1275 mm |
| <input type="checkbox"/> 275 mm | <input type="checkbox"/> 455 mm | <input type="checkbox"/> 1425 mm |
| <input type="checkbox"/> 290 mm | <input type="checkbox"/> 525 mm | <input type="checkbox"/> 1625 mm |
| <input type="checkbox"/> 315 mm | <input type="checkbox"/> 580 mm | <input type="checkbox"/> 1825 mm |
| <input type="checkbox"/> 340 mm | <input type="checkbox"/> 655 mm | <input type="checkbox"/> 2025 mm |
| <input type="checkbox"/> 375 mm | <input type="checkbox"/> 735 mm | <input type="checkbox"/> other length: _____ |

PROTECTING ARMATURES FOR GAUGE SLIDES

T752 MTC gauge slides with connection socket

T760 MTC gauge slides with 1 transmitter

T761 MTC gauge slides with 1 transmitter and with connection for the second transmitter

T752

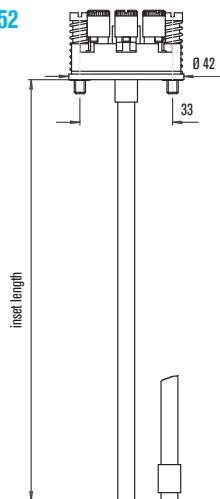

THERMOCOUPLE :

- 1 x L (T752 + T760)
- 1 x J (T752 + T760)
- 1 x K (T752 + T760)
- 2 x L (T752 + T761)
- 2 x J (T752 + T761)
- 2 x K (T752 + T761)

LIMIT DEVIATION / TYPE OF MEASURING TIP:

- class 1 / form A
- class 1 / form B
- class 2 / form A
- class 2 / form B

Ø JACKET / MEASURING TIP:

- 3.0
- 4.5
- 6.0
- 6.0/8.0

T760

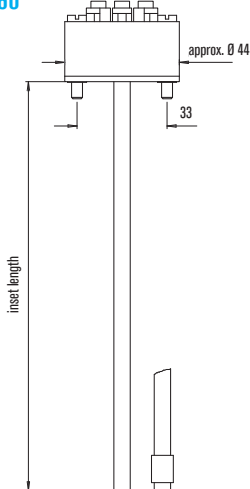

JACKET MATERIAL:

- 1.4541
- 2.4816

INSET LENGTH:

- 145 mm
- 205 mm
- 255 mm
- 275 mm
- 290 mm
- 315 mm
- 340 mm
- 375 mm
- 405 mm
- 430 mm
- 435 mm
- 455 mm
- 525 mm
- 580 mm
- 655 mm
- 735 mm
- 825 mm
- 1025 mm
- 1275 mm
- 1425 mm
- 1625 mm
- 1825 mm
- 2025 mm
- other length: _____

T761

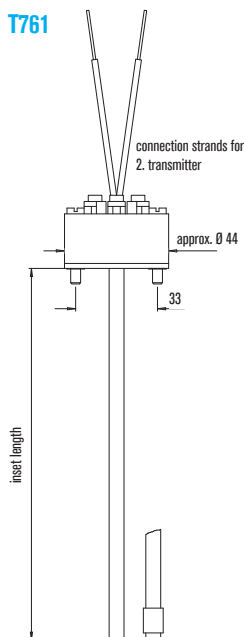

PROTECTING ARMATURES AND GAUGE SLIDES

ACCESSORIES

Connection heads

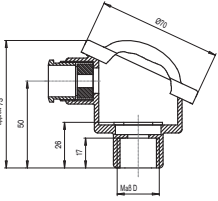
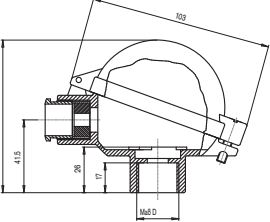
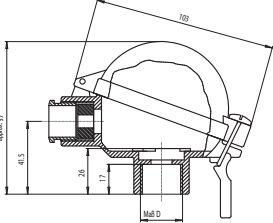
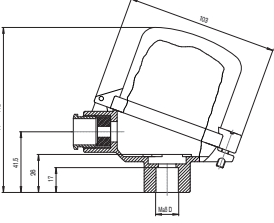
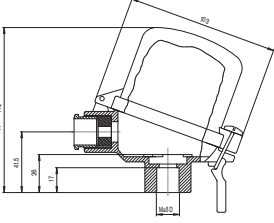
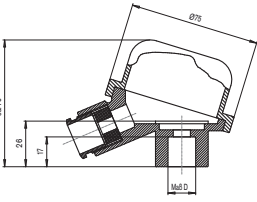
drawing	form	material	dim. D mm	protection system	SAB- type	weight approx. kg	item no.
	BA	light metal	Ø 15.8	IP 53	KE 021	0.14	lower part T030-031-667 cap T030-007-276
		die-cast	M 24 x 1.5	IP 54	KE 122	0.127	lower part T030-030-531 cap T030-007-276
	DAN-Z	light metal	Ø 15.8	IP 53	KE 063	0.254	T030-007-237
		die-cast	M 24 x 1.5	IP 65	KE 064	0.232	T030-007-238
	DAN-S	light metal	Ø 15.3	IP 53	KE 065	0.27	T030-037-035
		die-cast	M 24 x 1.5	IP 65	KE 066	0.243	T030-007-236
	DAN-WZ	light metal	Ø 15.3	IP 53	KE 201	0.31	T030-007-239
		die-cast	M 24 x 1.5	IP 65	KE 202	0.294	T030-007-240
	DAN-WS	light metal	Ø 15.3	IP 53	KE 203	0.32	T030-007-241
		die-cast	M 24 x 1.5	IP 65	KE 204	0.303	T030-007-242
	BNK	polyamide, black	Ø 15.8	IP 53	KK 028	0.083	T030-007-226
				M 24 x 1.5	IP 54	KK 029	0.071

PROTECTING ARMATURES FOR GAUGE SLIDES

ACCESSORIES

Clamp screw connections made of steel 1.0718 for...

MTE ø mm	thread	with pressure ring made of PTFE item no.
1.5	M 8 x 1	T 025-007-148
2.0	M 8 x 1	T 025-007-151
3.0	M 8 x 1	T 025-000-681
4.5	G 1/4 A	T 025-007-157
6.0	G 1/4 A	T 025-000-685

Clamp screw connections made of steel 1.0718 for...

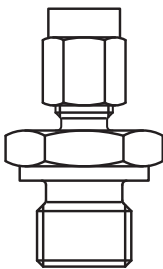

MTE ø mm	thread	with tapered ring made of stainless steel 1.4571 item no.
1.5	M 8 x 1	T 025-007-147
2.0	M 8 x 1	T 025-007-150
3.0	M 8 x 1	T 025-000-680
4.5	G 1/4 A	T 025-007-156
6.0	G 1/4 A	T 025-000-684

Clamp screw connections made of stainless steel 1.4571 for...

MTE ø mm	thread	with pressure ring made of PTFE item no.
1.5	M 8 x 1	T 025-007-146
2.0	M 8 x 1	T 025-007-149
3.0	M 8 x 1	T 025-007-153
4.5	G 1/4 A	T 025-007-155
6.0	G 1/4 A	T 025-007-160

Note:

Clamp screw connections with a thrust collar made of PTFE are appropriate for temperatures up to +200°C and for pressures up to 10 bar. Later loosening and moving is possible.

Clamp screw connections with a tapered ring made of steel or stainless steel are appropriate for temperatures above + 200°C and for pressures up to 40 bar. By tightening the screw connection, the tapered ring is fixed on the tube and can't be loosened anymore. Therefore, later loosening isn't possible at all.

Clamp screw connections made of stainless steel 1.4571 for...

MTE ø mm	thread	with tapered ring made of stainless steel 1.4571 item no.
1.5	M 8 x 1	T 025-007-145
3.0	M 8 x 1	T 025-007-152
4.5	G 1/4 A	T 025-007-154
6.0	G 1/4 A	T 025-007-159

PROTECTING ARMATURES FOR GAUGE SLIDES

ACCESSORIES

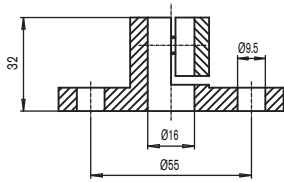

Stop flange acc. to DIN 43734
(p.e. construction form T411 and T413 on page 10)

for tube-Ø mm	material	SAB type	weight approx. kg	item no.
15.0	GTW-35	B 01	0.23	T 026-000-687

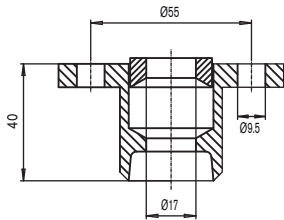

Mating flange acc. to DIN 43734
(p.e. construction form T411 and T413 on page 10)

for tube-Ø mm	material	SAB type	weight approx. kg	item no.
15.0	GTW-S38	B 10	0.28	T 026-006-124

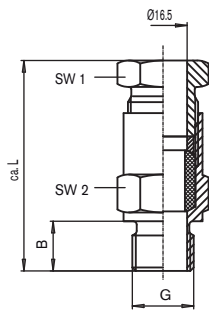

Adjustable screw socket, gas tight up to 1 bar made of mat. no. 1.0711 nickel plated (p.e. construction form T411 and T413 on page 10)

for tube-Ø mm	thread G	dim. B mm	dim. SW1 mm	dim. SW2 mm	dim. - L mm	SAB type	weight approx. kg	item no.
15.0	G 1/2 A	17	27	27	78	B 131	0.25	T 055-000-759
15.0	G 3/4 A	20	32	30	80	B 132 A	0.32	T 055-000-760
15.0	G 1/2 A	20	41	36	88	B 133 A	0.45	T 055-008-538

PROTECTING ARMATURES FOR GAUGE SLIDES

ACCESSORIES

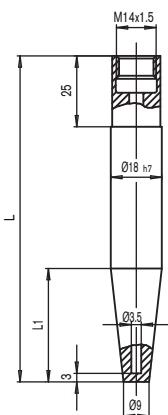

to T451

welding protecting tubes form D acc. to DIN 43763 for high pressures

form acc. to DIN	immersion length L mm	immersion length L1 mm	material no.	weight approx. kg	item no.
D4S - L D5S - L	140 115	65 40	1.7335 1.7335	0.20 0.17	T 052-011-430 T 052-011-431
D4S - M D5S - M	140 115	65 40	1.7380 1.7380	0.20 0.17	T 052-013-738 T 052-013-739
D4S - K D5S - K	140 115	65 40	1.4571 1.4571	0.20 0.17	T 052-011-428 T 052-011-429

* For all protecting tube materials there are acceptance certificates acc. to DIN 10204-3.1 B.
Welding protecting tubes with acceptance certificate 3.1 A (TÜV) acc. to DIN EN 10204 on request!

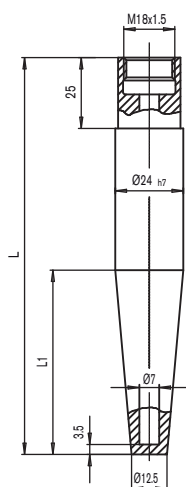

to T450

welding protecting tubes form DS acc. to DIN 43763 for high pressures

form acc. to DIN	immersion length L mm	immersion length L1 mm	material no.	weight approx. kg	item no.
D1 - L D2 - L D4 - L D5 - L	140 200 200 260	65 125 65 125	1.7335 1.7335 1.7335 1.7335	0.34 0.44 0.53 0.64	T 052-007-862 T 052-007-863 T 052-007-864 T 052-007-865
D1 - M D2 - M D4 - M D5 - M	140 200 200 260	65 125 65 125	1.7380 1.7380 1.7380 1.7380	0.34 0.44 0.53 0.64	T 052-007-866 T 052-007-867 T 052-007-868 T 052-007-869
D1 - K D2 - K D4 - K D5 - K	140 200 200 260	65 125 65 125	1.4571 1.4571 1.4571 1.4571	0.34 0.44 0.53 0.64	T 052-007-857 T 052-007-858 T 052-007-859 T 052-007-860

* For all protecting tube materials there are acceptance certificates acc. to DIN EN 10204-3.1 B.
Welding protecting tubes with acceptance certificate 3.1 A (TÜV) acc. to DIN EN 10204 on request!

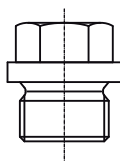

Screw plugs for above mentioned welding sleeves

thread acc. to 910	material	dimensions mm	item no.
M 18 x 1.5 M 14 x 1.5	nickel plated steel	0.05 0.03	T 026-007-199 T 026-007-198

Conical nipple for above mentioned welding sleeves

acc. to DIN	material	dimensions mm	item no.
form C 7603 form C 7603	Cu/KFC Cu/KFC	Ø 18 x 22 x 2 Ø 14 x 18 x 2	T 020-005-973 T 020-005-976

Please note that not all types are available from stock and that there are possibly min. order quantities!

For centuries people were only able to grasp temperatures subjectively as cold or hot. The invention of the first objective temperature measuring device based on the expansion of air goes back to Galileo Galilei approx. in 1592. Today temperature measurement technique disposes of a great number of highly specialized sensors and methods that allow to determine exactly and reproduce the thermodynamic state of the matter and thus its temperature almost between 0°K and for example the temperature of the sun.

■ The Fahrenheit scale

The German Gabriel Fahrenheit settled down in the Netherlands as instrument maker and built glass thermometers with mercury filling. In 1714 he divided the temperature range between a so called “cold mixture” (ice and salt) and the temperature of human blood (these were his points of reference) into 96 pieces. Later on it was determined in England that the solidification point of water corresponds to 32°F and its boiling point to 212°F.

■ The Celsius scale

In 1742 the Suede Anders Celsius divided the range between the solidification and boiling point of water into 100 pieces.

■ The Kelvin scale

In 1842 the Englishman William Thomson (later Lord Kelvin) developed on the basis of the Carnot process a thermodynamic temperature scale with the absolute zero point as reference and the scale interval of Celsius.

The conversion between the different scales is done as follows:

$$0 \text{ K} = - 273.15^{\circ}\text{C}$$
$$0^{\circ}\text{C} = + 273.15 \text{ K}$$

Electric thermometers turn the physical value of temperature into a dependent signal. They are self-contained constructive components that deliver an output signal for further treatment. Dependent on the sensor principle in most cases an auxiliary energy source is necessary.

An important advantage results out of the good transferability of those electric symbols over far distances. The transducer and indicator of temperature can be situated far away from each other. The measuring signals can be integrated and treated with small effort into control respectively process guiding systems.

1. Temperature as measured variable

For nearly all procedures in research and production, temperature is a factor to be considered. It is of considerable importance as measured variable. For temperature measurements, temperature dependent characteristics of materials can be used, as for example the changing electrical resistance (resistance thermometer), the electromagnetic radiation of hot bodies (radiation pyrometer) and resulting thermoelectric voltage (thermocouple). The different electric contact thermometers are frequently used for the field temperature measurement.

2. Physical basis

2.1. Resistance thermometer

Temperature measurement with the help of resistance thermometers is based on the special characteristic of conducting materials to change their resistance dependent on temperature. For metals the resistance increases with rising temperature. In case that the correlation between temperature and resistance is known, the temperature can be determined by resistance measurement. The suggestion to use the temperature dependent resistance of metal conductors for temperature measurement, was first made by Wilhelm von Siemens, the brother of Werner von Siemens in 1861 and was realized in the development of a thermometer for the measurement of deep sea temperatures. The works of H.L. Callendar made the resistance thermometer a precision device in 1886.

2.2. Thermocouples

The first basis of the thermovoltage effect was discovered by Seebeck in 1821. Thirty years later the exact correlations were found out by Thompson. The thermovoltage between 2 different metals depend on the thermal motion of electrons. It is not dependent on the absolute temperature values, but on temperature differences. The higher the temperature difference between "hot" and "cold", the higher the thermovoltage. The voltage at 1 degree Celsius is called the thermoelectric force of the thermocouple. It depends on the nature of the two materials whose connection point is heated.

3. The response time of contact thermometers

The temperature measurement with the help of contact thermometers is generally afflicted with a delayed indication. The result is that a changing temperature is not immediately indicated correctly but only after a certain time when the heat exchange between the measured medium and the temperature probe has been fully realized. This inertia of thermometers shall be as small as possible for certain measuring tasks. This is called the response time of a thermometer which means generally the time constant. Generally spoken: the time constant corresponds to the relation of the capacity of heat absorption and heat release of the thermometer. Both characteristics are mainly determined by:

- heat capacity
- transversal thermal conductivity of the thermometer
- relation of surface to volume of the thermometer
- coefficient of thermal conductivity between medium and surface of the thermometer as well as of the medium velocity, its thermal conductivity and its specific heat.

If a thermometer is suddenly exposed to another temperature, as for example by taking it out of water with a temperature of 20°C and putting it into water of 40°C, the indicated temperature rises almost according to the exponential function. The usual quantity for the changing velocity of such exponential procedures is the time constant. The time constant is equal to the time that passes until 63,2% of the temperature leap is indicated. In many cases, the temperature indication does not change according to the exponential function. For those cases the time constant is not sufficient to characterize the time response. Therefore it is useful to indicate the half-time z 0.5 and the 9/10 time value z 0.9. This is the definition of time from the sudden change of temperature to the reach of 50% either 90% of this temperature change. The exponential course shows z 0.5 = 0.693 (time constant) resp. z 0.9 = 2.303 (time constant) and the ratio z 0.9/ z 0.5 has to be equal to 3.32.

COMPARISON THERMOCOUPLES/ RESISTANCE THERMOMETERS

resistance thermometers

- ▶ Platinum resistance thermometers are the most accurate sensors and have the best long-time stability.
- ▶ due to the chemical resistance of Platinum, the risk of impurity by oxidation and other chemical influences is reduced.
- ▶ high consistency.

thermocouples

- ▶ larger temperature range than resistance thermometers.
- ▶ small hot junction enables short response time.
- ▶ more robust and resistant against mechanical stress.
- ▶ cheaper.

▶ General

A reliable temperature measurement requires a most exact adaptation to the corresponding process. This statement is valid for thermocouples as well as for resistance thermometers.

characteristics	resistance thermometer	thermocouples
▶ dimensions	comparatively large sensor surface	small sensor surface possible
▶ response time	relatively long	short
▶ connection cables	copper cables	thermo compensating cable
▶ accuracy	very good	good
▶ consistency	very good	satisfactory
▶ surface temperature measurement	not possible	possible
▶ hot junction	over the whole length of the RTD	punctual
▶ robustness	good	very good
▶ spontaneous heating	has to be considered	does not occur
▶ temperature range	up to +600°C	higher temperature possible
▶ cold junction	not necessary	necessary
▶ circuit supply	yes	no
▶ vibration resistance	relatively sensitive	very rugged

RESPONSE TIME MINERAL INSULATED THERMOCOUPLES/RESISTANCE THERMOMETERS

mineral insulated thermocouples

insulated hot junction		response time in		
(form A) jacket-Ø (mm)	water with 0.2 m/s		air with 2.0 m/s	
	t 0.5 (s)	t 0.9 (s)	t 0.5 (s)	t 0.9 (s)
0.5	0.06	0.13	1.80	5.50
1.0	0.15	0.50	3.00	10.00
1.5	0.21	0.60	8.00	25.00
3.0	1.20	2.90	23.00	80.00
4.5	2.50	5.90	37.00	120.00
6.0	4.00	9.60	60.00	200.00
8.0	7.00	17.00	100.00	360.00

welded hot junction		response time in		
(form B) jacket-Ø (mm)	water with 0.2 m/s		air with 2.0 m/s	
	t 0.5 (s)	t 0.9 (s)	t 0.5 (s)	t 0.9 (s)
0.5	0.03	0.10	1.80	6.00
1.0	0.06	0.18	3.00	10.00
1.5	0.13	0.40	8.00	25.00
3.0	0.22	0.75	23.00	80.00
4.5	0.45	1.60	33.00	110.00
6.0	0.55	2.60	55.00	185.00
8.0	0.75	4.60	97.00	310.00

mineral insulated resistance thermometer

jacket-Ø (mm)	response time in			
	water with 0.2 m/s		air with 2.0 m/s	
	t 0.5 (s)	t 0.9 (s)	t 0.5 (s)	t 0.9 (s)
1.6	3.6	5.5	10.8	26.3
3.0	5.2	9.8	20.0	51.0
6.0	10.4	23.2	46.8	121.0

These indications are only reference values as the response time depends on the applied RTD.

► General

Mineral insulated thermocouples and mineral insulated resistance thermometers can be bent with a radius of 5 x the outer diameter of the jacket material. Herewith it must be considered that any bending of the measuring tip over a length of 60 mm has to be avoided.

MATERIALS AND APPLICATION FIELDS

Choice of material

Unalloyed, high-temperature steel			
max. application temperature	mat.no.	material characteristics	application range
400°C	1.0305 (ASTM 105)	unalloyed steel	weld-in and screw-in protecting tubes in steam lines
500°C	1.5415 (AISI A204 Gr.A)	low-alloy and high-temp. steel with molybdenum addition	weld-in and screw-in protecting tubes
540°C	1.7335 (AISI A182 F11)	low-alloy and high-temp. steel with chromium and molybdenum addition	weld-in and screw-in protecting tubes
570°C	1.7380 (AISI A182 F22)	low-alloy and high-temp. steel with chromium and molybdenum addition	weld-in and screw-in protecting tubes
650°C	1.4961	high-temp. austenitic chromium nickel steel (Niobium stabilized)	weld-in and screw-in protecting tubes
Rust and acid resistant steel			
550°C*	1.4301 (AISI 304)	good resistance against organic acids with medium temperatures, saline solutions p.e. sulphates, sulphides, alkaline solvents with medium temp.	food and luxury, food industry, medical apparatus engineering
550°C*	1.4404 (AISI 316 L)	by the addition of molybdenum it is more corrosion-proof in oxidizing acids, p.e. acid of vinegar, acidity of wine, phosphoric acid, sulphuric acid and others. There is an elevated resistance against intercrystalline corrosion by a reduced carbon content.	chemical, pulp industry, nuclear technology, textile, color, fatty acid, soup and pharmaceutical industries as well as dairies and breweries
550°C*	1.4435 (AISI 316L)	elevated resistance against corrosion compared with 1.4404, smaller delta ferrite portion	pharmaceutical industries
550°C*	1.4541 (AISI 321)	good intercrystalline corrosion resistance, good resistance against heavy oil products, vapor and combustion gases. Good resistance against oxidation.	Chemical industry, nuclear power plants, textile, color, fatty acids, soap industry
550°C*	1.4571 (AISI 316 TI)	elevated corrosion resistance compared to certain acids due to the addition of molybdenum. Resistant against crevice corrosion, salt water and aggressive industrial influences.	pharmaceutical industry as well as dairies and breweries
Heat resistant steel			
1100°C	1.4749 (AISI 446)	very good resistance against sulphuric gases and salts due to the high chromium content, very good oxidation resistance as well as with constant and cyclic thermal stress, (low resistance against nitrogenated gases)	smoke and combustion gases, industrial furnaces
1200°C	1.4762 (AISI 446)	high resistance against sulphuric gases due to the high chromium content, (low resistance against nitrogenated gases)	smoke and combustion gases, industrial furnaces
1150°C	1.4841 (AISI 314)	high resistance against nitrogenated and lower oxygen gases. Permanent operation not below 900°C due to embrittlement (more heat resistant than 1.4749 and 1.4762)	power plant construction, petrochemistry, industrial furnaces
1150°C	1.4845 (AISI 310)	same characteristics as 1.4841, however advantage against sigma-phase-embrittlement due to the high portion of silicium	industrial furnace construction, apparatus construction, melting houses, power plant construction, petrochemistry, furnace tubes
1100°C	2.4816 (Inconel 600)	good corrosion resistance, resistance against stress corrosion cracking, excellent oxidation resistance, not recommended with CO ₂ and sulphuric gases above 550°C and sodium above	hydraulic reactors, nuclear power, industrial furnaces, steam boilers, turbines
1100°C	1.4876 (Incoloy 800)	due to the addition of titanium and aluminum the material shows very good heat resistant values. Appropriate for applications where high mechanical strength besides scaling resistance are demanded. Excellent resistance against carburization and nitrogen content increase.	hydraulic reactors, power plant construction, petrochemistry, industrial furnaces
1300°C	Pt 10% Rh platinum-rhodium alloy	1300°C with oxidizing conditions, in absence of oxygen, silicium and sulphur high heat resistance up to 1200°C, especially resistant in halogens, vinegar acid, NaOCl solutions etc., embrittlement by absorption of silicium out of armoring ceramics, phosphorous sensitiveness, inappropriate in reducing hydrogen atmospheres with sulphurous components.	glass, electrochemical and catalyst technique chemical industry, laboratories, melting houses, annealing furnaces

* In dependence on pressure stress and corrosion attack, the application temp. may reach up to 800°C

CHARGE DIAGRAMS OF PROTECTING TUBES

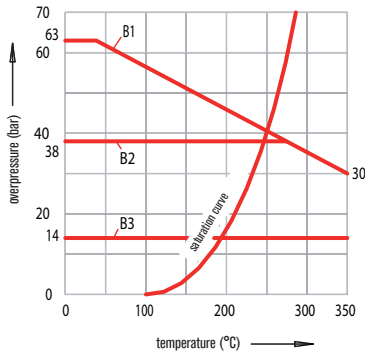

LOADING CAPACITY OF PROTECTING TUBES FORM B

material: St 35.8
(mat. no. 1.0305)

- allowed flow velocity
for air and hot vapor: 25 m/s
for water: 3 m/s
- allowed clamping torque of
the screwed plug: 50 Nm

LOADING CAPACITY OF PROTECTING TUBES FORM B

material: X 6 CrNiMoTi 17 122
(mat. no. 1.4571)
material: X 6 CrNiTi 1810
(mat. no. 1.4541)

- allowed flow velocity
for air and hot vapor: 25 m/s
for water: 3 m/s
- allowed clamping torque of
the screwed plug: 50 Nm

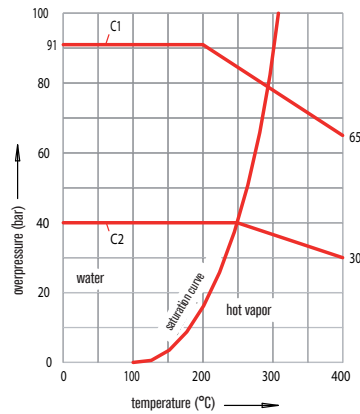
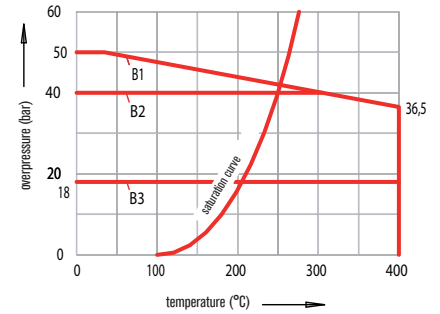

LOADING CAPACITY OF PROTECTING TUBES FORM C

material: St 35.8
(mat. no. 1.0305)

- allowed flow velocity
for air and hot vapor: 40 m/s
for water: 5 m/s
- allowed clamping torque of
the screwed plug: 100 Nm

LOADING CAPACITY OF PROTECTING TUBES FORM C

material: 13 CrMo 44
(mat. no. 1.7335)
material: X 6 CrNiMoTi 17 122
(mat. no. 1.4571)
material: X 6 CrNiTi 1810
(mat. no. 1.4541)

- allowed flow velocity
for air and hot vapor: 40 m/s
for water: 5 m/s
- allowed clamping torque of
the screwed plug: 100 Nm
- temperature limits for mat. no. 1.4571
and 1.4541: 400°C

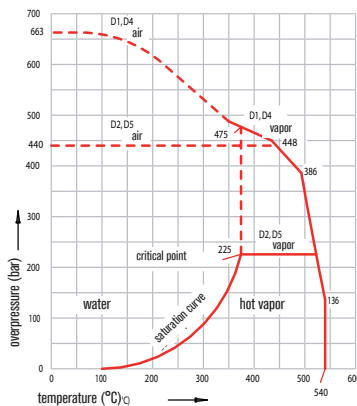
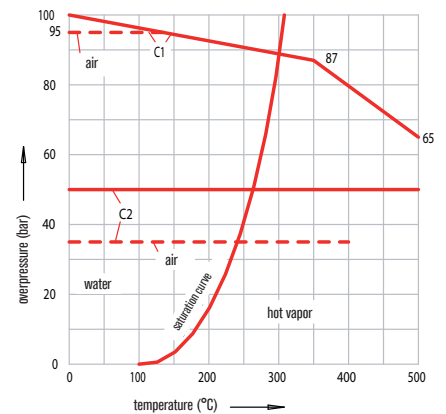

LOADING CAPACITY OF PROTECTING TUBES FORM D

material: 13 CrMo 44
(mat. no. 1.7335)

- allowed flow velocity
for air and hot vapor: 60 m/s
for water: up to 450 bar and up to 5 m/s

CHARGE DIAGRAMS OF PROTECTING TUBES

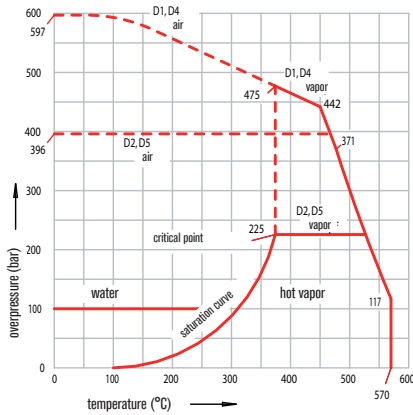

LOADING CAPACITY OF PROTECTING TUBES FORM D

material: 10 CrMo 910
(mat. no. 1.7380)

- allowed flow velocity for air and hot vapor: 60 m/s
- loading capacity in water: up to 450 bar and up to 5 m/s

LOADING CAPACITY OF PROTECTING TUBES FORM G

material: X 6 CrNiMoTi 17 122
(mat. no. 1.4571)
material: X 6 CrNiTi 1810
(mat. no. 1.4541)

- allowed flow velocity for hot vapor: 40 m/s
- for water: 5 m/s
- for air: bis 400 °C

form	10	20	30	40	m/s
G1	100	100	100	100	} bar
G2	100	100	98	58	
G3	100	100	58	38	

*due to flange PN 40
For the use of flanges PN 100
the charge values of form E are valid.

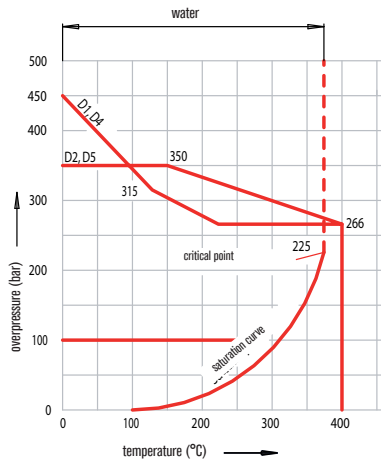
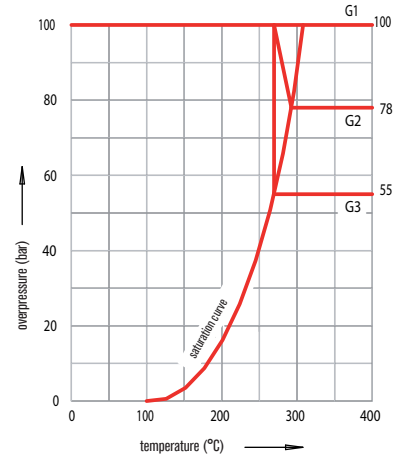

LOADING CAPACITY OF PROTECTING TUBES FORM D

material: X 6 CrNiMoTi 17 122
(mat. no. 1.4571)
material: X 6 CrNiTi 1810
(mat. no. 1.4541)

- protecting tubes D1 and D4: allowed flow velocity for air, water and hot vapor: 60 m/s
- protecting tubes D2 and D5: allowed flow velocity for air: up to 60 m/s for water and hot vapor: up to 30 m/s

LOADING CAPACITY OF PROTECTING TUBES FORM E+F

material: X 6 CrNiMoTi 17 122
(mat. no. 1.4571)
material: X 6 CrNiTi 1810
(mat. no. 1.4541)

- allowed flow velocity for hot vapor: 40 m/s
- for water: 5 m/s
- for air: up to 400 °C

form	10	20	30	40	m/s
F1 (E1)	40*(100)	40*(100)	40*(68)	40*(42)	} bar
F2 (E2)	40* (75)	40* (65)	40*(45)	25*(25)	
F3 (E3)	40* (58)	40* (45)	30*(30)	18*(18)	

*due to flange PN 40
For the use of flanges PN 100
the charge values of form E are valid.

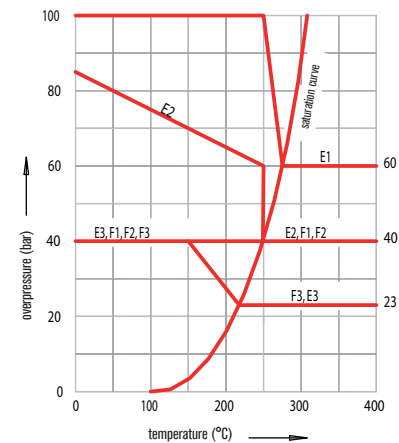

TECHNICAL DESCRIPTION OF GAUGE SLIDES

The gauge slides are available as thermocouples as follows:

- thermocouple: 1 x type K or 2 x type K
1 x type J or 2 x type J
1 x type L or 2 x type L
- limit deviation: class 1 or 2 acc. to DIN EN 60584 for types K and J
- limit deviation: with reference to DIN 43710 for type L
- jacket: \varnothing 1.5 mm; \varnothing 3.0 mm; \varnothing 4.5 mm; \varnothing 6.0 mm or 6.0 mm with measuring tip \varnothing 8.0 mm
- transmitter: with 1 or 2 transmitters

The gauge slides are available as resistance thermometers as follows:

- resistance thermometer: 1 x Pt 100 or
2 x Pt 100 in
2-, 3- and 4- wire circuit
- temperature range: $-50^{\circ}\text{C}/+400^{\circ}\text{C}$ or $-50^{\circ}\text{C}/+600^{\circ}\text{C}$
- limit deviation: class A or B acc. to DIN EN 60751
- jacket: \varnothing 1.6 mm; \varnothing 3.0 mm; \varnothing 4.5 mm; \varnothing 6.0 mm or
6.0 mm with measuring tip \varnothing 8.0 mm
- transmitter: with one or two transmitters

Every gauge slide manufactured at SAB has a type plate at its lower side indicating for example:

- **SAB** item no: T 752-041-724
- type/number of thermocouples: 2 x type K
- temperature range: $-40^{\circ}\text{C} / +1100^{\circ}\text{C}$
- **SAB** work order no.: T084815
- week and year of production: 37/07
- accuracy

TECHNICAL DESCRIPTION OF TRANSMITTERS

■ Transmitter

In order to avoid the problems of a 2-wire circuit (see page 41) and to do without a multi conductor cable, a 2-wire transmitter is used.

The transmitter transfers the probe signal into a standardized temperature linear current signal from 4...20 mA. The supply of the transmitter is equally done via the two connection cables. Therefore, a quiescent current of 4 mA is used. Due to the removed zero point, it is called "life zero".

Furthermore, the 2-wire transmitter offers the advantage to reduce the interference susceptibility by reinforcing the signal. For the mounting of the transmitters, 2 construction types are possible.

As the distance of the normal signal shall be kept as short as possible, it can be mounted directly in the head of the transmitter and thus the interference susceptibility is reduced.

Constructive conditions or the fact that the transmitter can't be reached easily in case of a defect are sometimes contradictory to this optimum solution.

In this case a transmitter for rail mounting in the switch cabinet is used.

The advantage of better access nevertheless results in a longer distance that the normal signal has to cover.

In all protecting armatures with a corresponding protection head transmitters can be mounted. A cheap solution is the direct mounting of the transmitter on the gauge slide (instead of ceramic socket). We recommend the mounting in the cap of a special connection head which enables a simple exchange and standard gauge slides can be used for replacement.

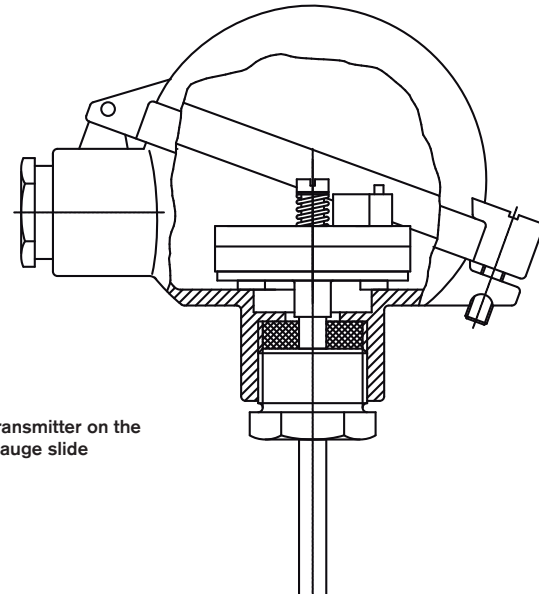

transmitter on the
gauge slide

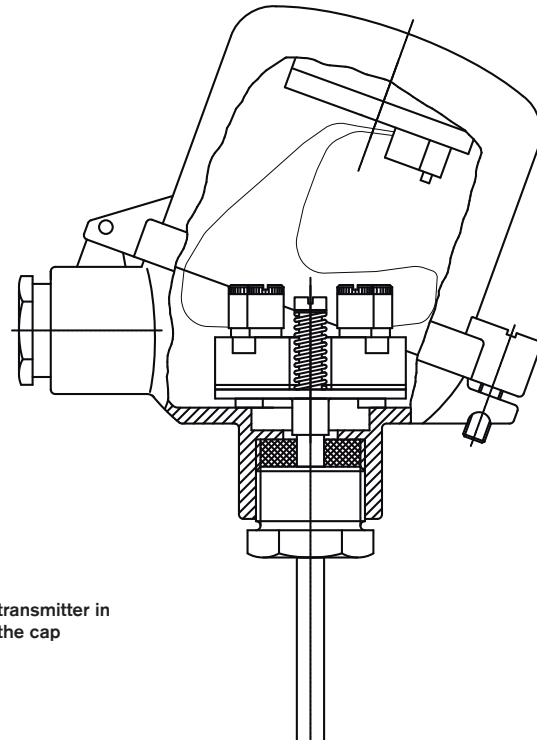

transmitter in
the cap

HALAR-COATING

- For the application in corrosive media, we are able to furnish flange protecting armatures with a Halar®-coating.

In many industrial branches an elevated protection against corrosion is demanded due to a higher capacity utilization, new technologies and production processes. An elevated chemical and mechanical stability are requested in order to reach a higher economic efficiency and productivity. For this reason we are offering a Halar®-coating in order to accomplish these requirements.

Halar® is an alternating ethylene chlorine trifluoride copolymer (E-CTFE) that has an excellent resistance against chemical, electric and mechanical stress. Furthermore, it possesses an elevated radiation and weather resistance.

Extensive tests executed with lots of chemicals have shown that Halar® is absolutely resistant against tension cracking. There weren't any chemicals dissolving Halar® fluoropolymers at temperatures up to + 120°C. One exception are chlorinated solvents that make Halar® swell at a certain degree but don't affect its characteristics. The maximum permanent operating temperature is about 160°C. Furthermore, Halar® has an elevated vacuum resistance and offers highest qualities with regard to viscosity, abrasion resistance, elasticity and notch resistance.

Coating thicknesses up to 1500µ can be reached. The min. coating thickness is 300µ.

Mechanical treatment after coating is always possible.

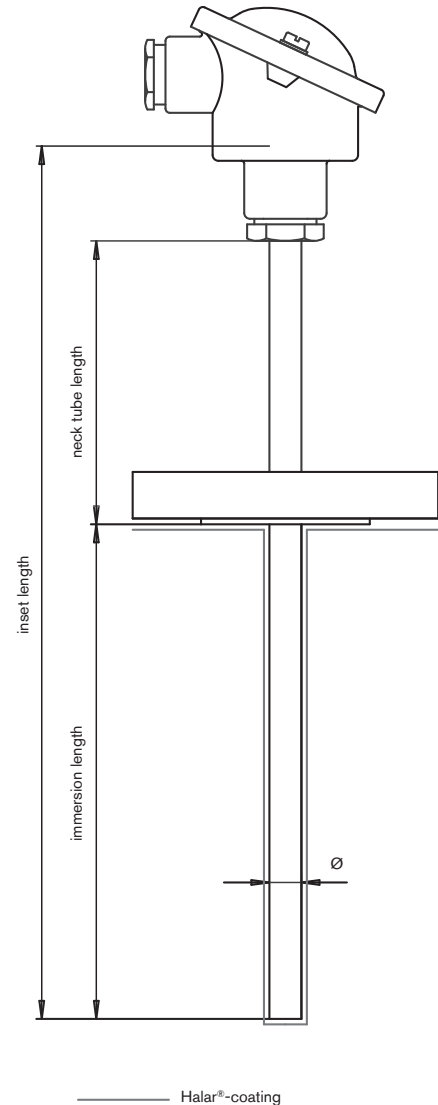

TEST CERTIFICATES

Test reports or test certificates acc. to DIN EN 10204 are available for an additional fee.

1. Declaration of compliance with the order acc. to DIN EN 10204-2.1

Manufacturer's declaration of compliance with the order without test results.

2. Test report acc. to DIN EN 10204-2.2 (batch certificate)

Manufacturer's declaration of compliance with the order, with test results based on non specific inspection.

3. Inspection certificate acc. to DIN EN 10204-3.1

Manufacturer's declaration of compliance with the order, with test results based on specific inspection.

The test unit and the execution of the test are determined in the product specification, in official or technical prescriptions and/ or order. The certificate is confirmed by a person independent of production and named by the manufacturer.

List of individual tests per measuring point available for an additional fee

calibration in "Kryostat" bath:

temperature range -50°C up to +50°C

calibration in oil bath:

temperature range +60°C up to +200°C

calibration in "Trockenblock-Kalibrator":

temperature range -30°C up to +165°C, +100°C up to +1100°C

response time in water:

determination of 0.1-time, 0.5-time and 0.9-time

response time in air:

determination of 0.1-time, 0.5-time and 0.9-time

BASIC THERMOCOUPLES/ CONNECTION CABLES

Temperature is an important factor in many areas concerning the environment, scientific research and production. It is a thermo-dynamic variable that defines the heat content of a material. Material strength changes with alternating temperature. As a consequence, the characteristics of materials have to be examined at different temperatures. To obtain a temperature value, defined temperature parameters are used. Here the parameters can be defined, for example, as the freezing and boiling points of water.

For temperature measurement temperature dependent characteristics of materials have to be taken into account. These include such things as thermal expansion (expansion thermometer), the dependence of the electric resistance of metallic conductors (electrical thermometer) and electromotive force (thermocouple) etc.. A temperature measuring device with a thermocouple as a data indicator tends to consist of the thermometer itself with a measuring point, an extension cable, a cold junction with a specified constant temperature and a voltmeter.

The value of the electromotive force (EMF) produced by the thermocouple is determined by the difference between the measuring temperature and the so-called free ends of the thermocouple which are mounted in the connection head. As the connection head is usually relatively close to the measuring point, it is frequently exposed to temperature fluctuations. For this reason, a connection cable with the same thermo-electric properties as the thermocouple is used between the thermocouple and the cold junction.

■ Materials

We differentiate between thermocouple cable and compensating cable. Cables made of original materials are called extension or thermocouple cables, whereas conductor materials made of substitutes are known as compensating cables.

■ Compensating cables

The compensating wires and strands are composed of alloys which do not have to be identical with the corresponding thermocouple. Substitute material means that the thermo-electric characteristics in the allowed temperature range (usually 0 up to +200 °C) for the compensating cable must be the same as those of the corresponding thermocouple. They are identified with the letter "C" adapted to DIN IEC 584. The "C" appears behind the code letter identifying the thermocouple, for example "KC".

■ Extension cables

Extension cables are made of conductors with identical nominal structure to the corresponding thermocouple. They are identified with the letter "X" adapted to DIN IEC 584 which appears behind the code letter identifying the thermocouple, for example "JX". They are normally tested within a temperature range of 0 up to +200°C.

■ Thermocouple cables

Thermocouple cables consist of the same element material as the thermocouple and are tested for the same temperatures. These SAB special cables are manufactured on customer request. PVC, fiber-glass and SABtex insulated or jacketed compensating and extension cables are not suitable for outdoor use. Exception: PVC jacketed solid conductors can be used for underground laying.

Cables for resistance thermometers

Cables with copper conductors have to be laid between thermometer and measuring device. In order to keep faults by cable resistances and their temperature dependent fluctuations as small as possible, an appropriate cable section has to be chosen. Resistance thermometers are manufactured in 2-, 3-, and 4-wire circuit dependent on the required accuracy. By choosing the wire circuit it has to be considered that the cable resistance fully affects the measuring result.

The cables have to be chosen that they are appropriate for their environment that means that they resist against thermal, mechanical and chemical influences. All cable contacts have to be well done. Measuring cable shall be laid > 0.5 m away from any energy cable. In order to suppress electromagnetic or magnetic interferences, the cables shall be shielded and have twisted pairs.

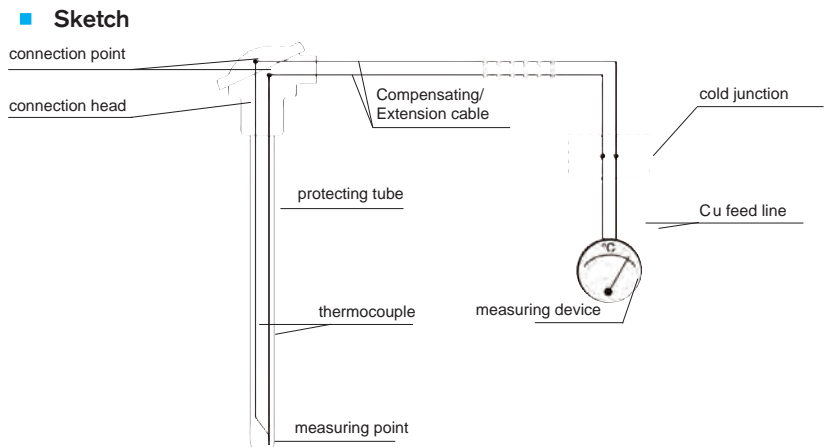

BASIC VALUES OF THERMOELECTRIC VOLTAGE IN MV

temperature t 90°C	type K	type L	type J	type U	type T	type E	type N	type S	type R	type B
	+NiCr -Ni	+Fe -CuNi	+Fe -CuNi	+ECu -CuNi	+ECu -CuNi	+NiCr -CuNi	+NiCrSi -NiSi	+PtRh 10 -Pt	+PtRh 13 -Pt	+PtRh 30 -PtRh 6
	DIN EN 60584	⁽¹⁾ DIN 43710	DIN EN 60584	⁽¹⁾ DIN 43710	DIN EN 60584	DIN EN 60584	DIN EN 60584	DIN EN 60584	DIN EN 60584	DIN EN 60584
-100	- 3.554	- 4.75	- 4.633	- 3.40	- 3.379	-5.237	-2.407	-	-	-
0	0	0	0	0	0	0	0	0	0	0
100	4.096	5.37	5.269	4.25	4.279	6.319	2.774	0.646	0.647	0.033
200	8.138	10.95	10.779	9.20	9.288	13.421	5.913	1.441	1.469	0.178
300	12.209	16.56	16.327	14.90	14.862	21.036	9.341	2.323	2.401	0.431
400	16.397	22.16	21.848	21.00	20.872	28.946	12.974	3.259	3.408	0.787
500	20.644	27.85	27.393	27.41	-	37.005	16.748	4.233	4.471	1.242
600	24.905	33.67	33.102	34.31	-	45.093	20.613	5.239	5.583	1.972
700	29.129	39.72	39.132	-	-	53.112	24.527	6.275	6.743	2.431
800	33.275	46.22	-	-	-	61.017	28.455	7.345	7.950	3.154
900	37.326	53.14	-	-	-	68.787	32.371	8.449	9.205	3.957
1000	41.276	-	-	-	-	76.373	36.256	9.587	10.506	4.834
1100	45.119	-	-	-	-	-	40.087	10.757	11.850	5.780
1200	48.838	-	-	-	-	-	43.846	11.951	13.228	6.786
1250	50.644	-	-	-	-	-	45.694	12.554	13.926	7.311
1300	52.410	-	-	-	-	-	47.513	13.159	14.629	7.848
1400	-	-	-	-	-	-	-	14.373	16.040	8.956
1450	-	-	-	-	-	-	-	14.978	16.746	9.524
1500	-	-	-	-	-	-	-	-	-	10.099
1600	-	-	-	-	-	-	-	-	-	11.263
1700	-	-	-	-	-	-	-	-	-	12.433

⁽¹⁾Since April 1994 the standard DIN 43710 is no longer valid

Thermoelectric voltage in mV with reference to a cold junction temperature of 0°C.

TOLERANCE MINERAL INSULATED THERMOCOUPLES

tolerances of outer diameter

tolerance of outer diameter	
outer-Ø of thermocouples	nominal value +/- limit dimensions
0.5 mm	+/- 0.025 mm
1.0 mm	+/- 0.025 mm
1.5 mm	+/- 0.025 mm
2.0 mm	+/- 0.025 mm
3.0 mm	+/- 0.030 mm
4.5 mm	+/- 0.045 mm
6.0 mm	+/- 0.060 mm
8.0 mm	+/- 0.080 mm

thermocouple types: form A / form B

Mineral insulated thermocouples listed in this catalog are according to DIN EN 61515 with regard to shape, construction and geometrical dimensions or refer to it. Regarding the basic values and tolerances the standards DIN EN 60584-1 and DIN EN 60584-2 are valid. We furnish mineral insulated thermocouples with insulated hot junction (form A) as standard version acc. to DIN EN 61515.

Form A – ungrounded mineral insulated thermocouple

▶ The measuring tip isn't directly welded to the bottom. Mineral insulated thermocouples keep the given min. insulation resistance acc. to DIN EN 61515 of >1000 MΩ at room temperature.

Form B – grounded mineral insulated thermocouple

▶ The measuring tip is electrically connected to the jacket.

tolerances of length

tolerances of length		
cutting length (mm)	cutting length up to (mm)	tolerances in (mm)
0	300	+/- 2
300	1000	+/- 4
1000	∞	+/- 10



special tolerances
acc. to agreement

tolerances of thermocouples

type	standard	material	class 1		class 2		class 3	
			temperature range	(2) limit deviation	temperature range	(2) limit deviation	temperature range	(2) limit deviation
T	DIN EN 60584	Cu-CuNi	-40 up to +350°C	±0.5°C or 0.40%	-40 up to +350°C	±1.0°C or 0.75%	-200 up to +40°C	±1.0°C or 1.5%
⁽¹⁾ U	DIN 43710	Cu-CuNi	–	–	0 up to +600°C	±3.0°C or 0.75%	–	–
J	DIN EN 60584	Fe-CuNi	-40 up to +750°C	±1.5°C or 0.40%	-40 up to +750°C	±2.5°C or 0.75%	–	–
⁽¹⁾ L	DIN 43710	Fe-CuNi	–	–	0 up to +900°C	±3.0°C or 0.75%	–	–
K	DIN EN 60584	NiCr-Ni	-40 up to +1000°C	±1.5°C or 0.40%	-40 up to +1200°C	±2.5°C or 0.75%	-200 up to +40°C	±2.5°C or 1.5%
E	DIN EN 60584	NiCr-CuNi	-40 up to +800°C	±1.5°C or 0.40%	-40 up to +900°C	±2.5°C or 0.75%	-200 up to +40°C	±2.5°C or 1.5%
N	DIN EN 60584	NiCrSi-NiSi	-40 up to +1000°C	±1.5°C or 0.40%	-40 up to +1200°C	±2.5°C or 0.75%	-200 up to +40°C	±2.5°C or 1.5%
S	DIN EN 60584	PtRh 10-Pt	0 up to +1600°C	±1.0°C or ⁽³⁾	0 up to +1600°C	±1.5°C or 0.25%	–	–
R	DIN EN 60584	PtRh13-Pt	0 up to +1600°C	±1.0°C or ⁽³⁾	0 up to +1600°C	±1.5°C or 0.25%	–	–
B	DIN EN 60584	PtRh30-PtRh6	–	–	+600 up to +1700°C	±1.5°C or 0.25%	+600 up to +1700°C	±4.0°C or 0.5%

Classes 1, 2, and 3 are valid for thermocouples.

⁽¹⁾ Since April 1994 the standard DIN 43710 is no longer valid.





































⁽²⁾ For the limit deviation, the higher value is valid.

⁽³⁾ 1°C or $[1 + (t - 1100) \times 0.003]$ °C

CHARACTERISTICS OF THERMOCOUPLES

characteristics thermocouples	general	composition	temperature range	suitable application	unsuitable application
type E	base metal thermocouple NiCr - CuNi (nickel-chrome/copper-nickel) single wires made of non precious metals	EP-leg: 89-90% nickel, 9-9.5% chrome, 0.5% silicium and iron, balance: C, Mn, Nb, Co EN-leg: 55% copper, 45% nickel, approx. 0.1% cobalt, iron and manganese	-200°C/+700°C	<ul style="list-style-type: none"> ▶ in pure, oxidizing (air) or neutral atmosphere (inert gases) ▶ high resistance against corrosion ▶ small thermal conductivity 	<ul style="list-style-type: none"> ▶ do not apply in sulphuric, reducing or alternately oxidizing and reducing atmosphere ▶ do not apply in vacuum for a long time
type J	base metal thermocouple Fe - CuNi (iron/copper-nickel) single wires made of non precious metals	JP-leg: 99.5% iron, approx. 0.25% manganese, approx. 0.12% copper, balance: other impurities JN-leg: 55% copper, 45% nickel, approx. 0.1% cobalt, iron and manganese	-180°C/+700°C	<ul style="list-style-type: none"> ▶ from 0 - +760°C in vacuum, oxidizing (air), reducing or inert atmosphere (inert gases) 	<ul style="list-style-type: none"> ▶ temperatures below 0°C ▶ sulphurous atmosphere above +500°C ▶ above +760°C only with bigger wire diameters
type K	base thermocouple NiCr - NiAl (nickel-chrome/nickel-aluminum) single wires made of non precious metals	KP-leg: 89-90% nickel, 9-9.5% chrome, 0.5% silicium and iron, balance: C, Mn, Nb, Co KN-leg: 95-96% nickel, 1-1.5% silicium, 1-2.3% aluminum, 1-3.2% manganese, 0.5% cobalt, balance: Fe, Cu, Pb	-270°C/+1372°C	<ul style="list-style-type: none"> ▶ from +250°C - +1260°C in pure, oxidizing (air) and neutral atmosphere (inert gases) ▶ for higher temperatures bigger wire diameters are recommended 	<ul style="list-style-type: none"> ▶ between +250°C up to +600°C not suitable for exact measurements with quick temperature changes ▶ not appropriate for a longer time with high temperatures in vacuum ▶ do not apply with high temperatures in sulphurous, reducing or alternately oxidizing and reducing atmosphere without protection ▶ do not use in atmosphere prone to "green mold"
type L	base thermocouple Fe - CuNi (iron/copper-nickel) single wires made of non precious metals	LP-leg: 99.5% iron, approx. 0.25% manganese, approx. 0.12% copper, balance: other impurities LN-leg: 55% copper, 45% nickel, approx. 0.1% cobalt, iron and manganese	0°C/+900°C	<ul style="list-style-type: none"> ▶ from 0°C - +760°C in vacuum, oxidizing (air), reducing or inert atmosphere (inert gases) ▶ above +500°C bigger wire diameters are recommended 	<ul style="list-style-type: none"> ▶ temperatures below 0°C ▶ sulphurous atmosphere above +500°C ▶ above +760°C only with bigger wire diameters
type N	base thermocouple NiCrSi - NiSi (nickel-chrome-silicium/nickel-silicium-magnesium) single wires made of non precious metals	NP-leg: 84% nickel, 14-14.4% chrome, 1.3-1.6% silicium, balance (not more than 0.1%): Mn, Fe, C, Co NN-leg: 95% nickel, 4.2-4.6% silicium, 0.5-1.5% magnesium, balance: Fe, Co, Mn, C, (altogether 0.1-0.3%)	-270°C/+1300°C	<ul style="list-style-type: none"> ▶ from +300°C - +1260°C in pure, oxidizing (air) and neutral atmosphere (inert gases) 	<ul style="list-style-type: none"> ▶ do not use with high temperatures in sulphurous, reducing or alternately oxidizing and reducing atmosphere without protection ▶ do not use with high temperatures in vacuum ▶ do not use in atmosphere with "green mold" ▶ reducing atmosphere
type R	base thermocouple Pt13%Rh - Pt (platinum 13% rhodium/platinum) single wires made of platinum and platinum-rhodium alloy	RP-leg: platinum with 99.99% purity with a rhodium alloy (purity 99.98%) 13±0.05% rhodium portion RN-leg: platinum with 99.99% purity	-50°C/+1768,1°C (melting point) recommended: up to +1300°C	<ul style="list-style-type: none"> ▶ pure, oxidizing atmosphere (air), non aggressive (inert-) gases and short-term in vacuum ▶ above +1200°C type B more appropriate 	<ul style="list-style-type: none"> ▶ reducing atmosphere ▶ metal gases (for example plumb or zinc) ▶ aggressive vapors containing arsenic, phosphor or sulphur ▶ do never use metal protecting tubes with higher temperatures ▶ sensitive against impurities of impure metals
type S	base thermocouple Pt10%Rh - Pt (platinum 10%rhodium/platinum) single wires made of platinum and platinum-rhodium alloy	SP-leg: platinum with 99.99% purity with a rhodium alloy (purity 99.98%) 10±0.05% rhodium portion SN-leg: platinum with 99.99% purity	-50°C/+1768,1°C (melting point) recommended: up to +1300°C	<ul style="list-style-type: none"> ▶ pure, oxidizing atmospheres (air), non aggressive (inert-) gases and short-term in vacuum ▶ above +1200°C type B more appropriate 	<ul style="list-style-type: none"> ▶ reducing atmosphere ▶ metal gases (for example plumb or zinck) ▶ aggressive vapors containing arsenic, phosphor or sulphur ▶ do never use metal protecting tubes with higher temperatures ▶ sensitive against impurities of impure metals
type B	base thermocouple (Pt30%Rh - Pt6%Rh platinum - 0% rhodium/ platinum-6% rhodium) single wires made of platinum and platinum-rhodium alloy	BP-leg: platinum with 99.99% purity with a rhodium alloy (purity 99.98%) 29.60±0.2% rhodium portion BN-leg: platinum with 99.99% purity with a rhodium alloy (purity 99.98%) 6.12±0.02% rhodium portion	max. +1820°C (melting point) ordinary up to +1700°C	<ul style="list-style-type: none"> ▶ pure, oxidizing atmosphere ▶ neutral atmospheres ▶ vacuum 	<ul style="list-style-type: none"> ▶ reducing atmosphere or such with aggressive vapors or impurities which react with metals of the platinum group, if it isn't protected with a non metal protecting tube
type T	base thermocouple Cu - CuNi (copper/copper-nickel) single wires made of non precious metals	TP-leg: 99.95% copper, 0.02-0.07% oxygen, 0.01% impurities TN-leg: 55% copper, 45% nickel, approx. 0.1% cobalt, iron and manganese	-270°C/+400°C	<ul style="list-style-type: none"> ▶ from -200°C - +370°C in vacuum, oxidizing (air), reducing or inert atmosphere (inert gases) ▶ with higher temperatures bigger wire diameters are recommended 	<ul style="list-style-type: none"> ▶ above +370°C not appropriate in a hydrogen atmosphere ▶ not appropriate in radioactive environment
type U	base thermocouple Cu - CuNi (copper/copper-nickel) single wires made of non precious metals	UP-leg: 99.95% copper, 0.02-0.07% oxygen, 0.01% impurities UN-leg: 55% copper, 45% nickel, approx. 0.1% cobalt, iron and manganese	0°C/+600°C (+400°C)	<ul style="list-style-type: none"> ▶ from -200°C - +370°C in vacuum, oxidizing (air), reducing or inert atmosphere (inert gases) ▶ with higher temperatures bigger wire diameters are recommended 	<ul style="list-style-type: none"> ▶ above +370°C not appropriate in a hydrogen atmosphere ▶ not appropriate in radioactive environment

COLOR CODE AND TEMPERATURE RANGE

THERMOCOUPLE							
Code	Material ⊕ ⊖	Identification		Identification		Identification	
		THL	AGL	THL	AGL	THL	AGL
T	Cu - Cu Ni	 TX -25° to +100°C		 0° to +100°C	 0° to +100°C	 -25° to +200°C	
U	Cu - Cu Ni		 UX 0° to +200°C				
J	Fe - Cu Ni	 JX -25° to +200°C		 0° to +200°C	 0° to +200°C	 -25° to +200°C	
L	Fe - Cu Ni		 LX 0° to +200°C				
E	Ni Cr - Cu Ni	 EX -25° to +200°C		 0° to +200°C	 0° to +200°C	 -25° to +200°C	
K	Ni Cr - Ni	 KX -25° to +200°C		 0° to +200°C	 0° to +200°C	 -25° to +200°C	
K	Ni Cr - Ni	 KCA 0° to +150°C				 0° to +150°C	
K	Ni Cr - Ni	 KCB 0° to +100°C			 0° to +100°C	 0° to +100°C	
N	Ni Cr Si - Ni Si	 NX -25° to +200°C	 NC 0° to +150°C				
R S	Pt Rh 13 - Pt Pt Rh 10 - Pt	 RCB/ SCB 0° to +200°C		 0° to +200°C	 0° to +200°C	 0° to +200°C	
B	Pt Rh 30 - Pt Rh 6			 0° to +100°C		 0° to +100°C	

The application temperature range of the cable is limited by the highest application temperature of the insulating material or the application temperature range of the conductor material. In all cases the respective lower figure is valid. The compensating cable for the thermocouple type B can also be manufactured, deviating from the corresponding standards, for a temperature range from 0 to +200°C (SAB-Type BC-200). Variant color codes can be manufactured for a minimum order quantity.

* The standard 43710 was withdrawn in April 1994.
Therefore, the element types "U" and "L" are not standardized anymore.

THL = extension cable · AGL = compensating cable

BASICS OF RESISTANCE THERMOMETERS

Resistance thermometers change their electrical resistance in dependence on the temperature or in other words resistance thermometers use the fact that the electrical resistance of an electrical conductor varies with changing temperature. In order to collect the output signal, the resistance is fed with a constant measuring current and the created voltage drop is measured. Platinum RTDs Pt 100, Pt 500 and Pt 1000 are used as measuring probes. They are standardized acc. to DIN EN 60751. Their resistance is 100 Ω at 0°C. The most different construction types of platinum resistance thermometers are applied in industrial measuring technique.

Our standard mineral insulated resistance thermometers are delivered for measuring ranges from - 50 °C up to + 400 °C and - 50 °C up to + 600 °. This indicated measuring range refers to the allowed temperature at the measuring tip of the resistance thermometer. In those temperature ranges the Pt 100 resistance thermometer is situated in a fixed characteristic line. Deviations from this characteristic line, also called basic values, are approved according to 2 tolerance classes A and B. Limit deviations please see page 38.

Platinum resistance thermometers are the most accurate sensors and show an excellent long-time stability. Due to the chemical insensitiveness of the platinum, the risk of contamination by oxidation and other chemical influences is reduced.

- high chemical resistance
- consistency
- long-term stability
- easy treatment

The standard value for the accuracy of platinum resistance thermometers is approx. ± 0.5 % of the measured temperature. They are applied in nearly all fields of industrial temperature measurement.

A reliable temperature measurement requires a most exact adaptation to the corresponding process. This statement can be applied for thermocouples as well as for resistance thermometers. Thermocouples in contrast to resistance thermometers are more simple, more robust, mostly cheaper, applicable in a broad temperature range and have small measuring points. Due to the punctual measurement with thermocouples, they have a quicker response time than resistance thermometers.

Resistance thermometers, however, have a high accuracy and reproducibility and the measuring points are a little bit bigger than those of thermocouples. Due to the planar measurement with resistance thermometers for reasons of construction, they show a slower response time.

TECHNICAL DESCRIPTION OF MINERAL INSULATED RESISTANCE THERMOMETERS

Technical description

1. General information

In general SAB BRÖCKSKES furnishes its insulated resistance thermometers with Platinum Pt 100 acc. to DIN EN 60751. On request we are also able to deliver mineral insulated resistance thermometers with Pt 500, Pt 1000. We recommend the use of Platinum RTDs due to their high level of stability and consistency. Mineral insulated resistance thermometers are often used for temperature measurement in containers, tubes, appliances and machines. They are applied whenever the flexible mounting and dismantling of the measuring probes are of great importance. Please note that mineral insulated resistance thermometers are only appropriate for low pressures and small flow rates.

2. Construction

The flexible and thin special steel tube of jacket contains 2, 4, or 6 inner wires which are pressed into magnesium oxide. The measuring resistance is connected to the inner wires and embedded into magnesium oxide powder. In general, material no. 1.4541 is used as jacket material.

3. Response times

Mineral insulated thermometers have short response times and react quickly onto changing temperatures. You will find the approximate values in the table on page 24.

BASIC VALUES OF RTDS

■ Accuracy classes acc. to DIN EN 60751:2009-5

class	validity range °C		limit deviation* °C
	lead resistor	film resistor	
AA	-50 up to +250	0 up to +150	± (0.10 + 0.0017 [t])
A	-100 up to +450	-30 up to +300	± (0.15 + 0.002 [t])
B	-196 up to +600	-50 up to +500	± (0.30 + 0.005 [t])
C	-196 up to +600	-50 up to +600	± (0.60 + 0.01 [t])

^a [t] = Value of temperature in °C without considering the sign.

For resistance thermometers that belong to the above context, the temperature coefficient α is defined as:

$$\alpha = \frac{R_{100} - R_0}{100 \times R_0} = \text{and has the numerical value } 0.003851/^{\circ}\text{C}$$

with: R_{100} is the resistance at 100°C and R_0 is the resistance at 0°C.

■ Limit deviations for PT 100 thermometers

abbreviation of RTD Pt 100 DIN EN 60751					
RTD material platinum					
application range -200 up to + 850 °C (class B)					
ITS 90 resistance and permitted deviation					
measuring temperature °C	basic value Ω	allowed deviation			
		class A		class B	
		Ω	°C	Ω	°C
-200	18.52	±0.24	±0.55	±0.56	±1.30
-100	60.26	±0.14	±0.35	±0.32	±0.80
0	100.00	±0.06	±0.15	±0.12	±0.30
100	138.51	±0.13	±0.35	±0.30	±0.80
200	175.86	±0.20	±0.55	±0.48	±1.30
300	212.05	±0.27	±0.75	±0.64	±1.80
400	247.09	±0.33	±0.95	±0.79	±2.30
500	280.98	±0.38	±1.15	±0.93	±2.80
600	313.71	±0.43	±1.35	±1.06	±3.30
650	329.64	±0.46	±1.45	±1.13	±3.60
700	345.28	-	-	±1.17	±3.80
800	375.70	-	-	±1.28	±4.30
850	390.48	-	-	±1.34	±4.60

for the term "basic values" see DIN 16160 part 5.

Resistance thermometers with different accuracy classes and validity ranges as for example acc. to DIN EN 60751: 2009-5 (class AA) are available on request.

TERMINAL CONNECTION/ COLOR CODE CONNECTION SOCKET

Resistance thermometer – gauge slides

	1 x Pt 100	2 x Pt 100	3 x Pt 100
2-wire circuit	<p>without identification</p>	<p>yellow</p>	<p>yellow</p> <p>red</p>
3-wire circuit	<p>red</p>	<p>red</p> <p>yellow</p> <p>black</p>	
4-wire circuit	<p>yellow</p> <p>red</p>	<p>red</p> <p>yellow</p>	
from connection socket in 4-wire circuit		<p>red</p> <p>yellow</p>	

Thermocouple – gauge slides

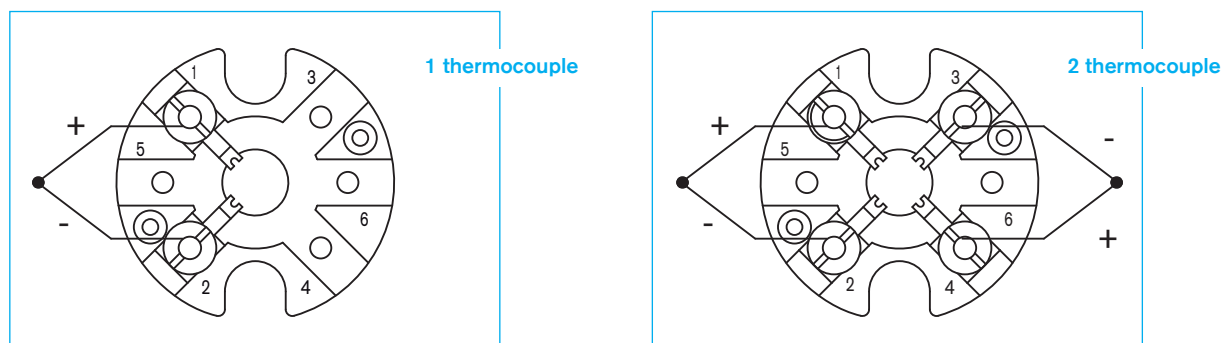

CONNECTION OF RESISTANCE THERMOMETERS

■ Connection of resistance thermometers

Resistance thermometers change their electrical resistance in dependence on temperature. In order to record the output signal, the line drop created by a constant measuring circuit is measured. Acc. to the Ohm's law the following is valid for this line drop: $U = R \times I$

In order to avoid the heating of the sensor, a small measuring circuit shall be chosen. A measuring circuit of 1 mA doesn't have any considerable impact. This current creates a line drop of 0.1 V with a PT 100 at 0°C. This measuring voltage has to be transferred to the display for evaluation as accurately as possible. We distinguish between four connection techniques:

■ 2-wire circuit

The connection between evaluation unit and thermometer is made by a 2 conductor cable. Like any other electrical conductor such a cable has a resistance itself in serial mounting with the resistance thermometer. Thus the two resistances are added that is interpreted as a higher temperature by the processing unit. In case of far distances the cable resistance can amount to several ohms and in this way falsify the measuring result.

example:

cable section: 0.35 mm²

spec. resistance: 0.0175 Ω mm² m⁻¹

cable length: 50 m

cable material: E-copper (E-CU) $R = 0.0175 \text{ } \Omega \text{ mms}^2 \text{ m}^{-1} \times \quad \quad \quad = 5.0 \text{ } \Omega$

5.0 Ω correspond to a temperature change of 12.8 °C with a Pt 100. In order to avoid this fault, the cable resistance is compensated electrically: The electronic unit is designed in a way that always a cable resistance of 10 Ω is considered. When the resistance thermometer is connected, a balancing resistance is connected into one of the measuring cables and first of all the sensor is replaced by a 100-Ω-resistance. Now the balancing resistance is changed as long as the display unit shows 0°C. The balancing resistance together with the cable resistance amount to 10 Ω. In most cases the balancing resistance wire is wound so that the balance is done by unwinding the wire. Due to this extensive balancing work, and the unknown temperature impact on the measuring cable, the 2-wire circuit is declining.

■ 3-wire circuit

In order to minimize the influences of the cable resistance and its temperature dependant fluctuations, the 3-wire circuit is frequently used instead of the above mentioned 2-wire circuit. Therefore, an additional cable is led to a contact of the RTD. Thus 2 measuring circuits are created, one of them being used as reference. Due to the 3-wire circuit, the cable resistance is compensated with regard to its amount as well as with regard to its temperature dependence provided that the 3 conductors have the same characteristics and are exposed to the same temperature. Thus a compensation of the cable resistance is no longer necessary.

■ 4-wire circuit

The best connection type for resistance thermometers is the 4-wire circuit. The measuring result is neither influenced by the cable resistance nor by their temperature dependant fluctuations. A compensation of the cable resistance is no longer necessary. The thermometer is fed with the measuring circuit via cable. Is the incoming resistance of the topped electronics a multiple of the cable resistance, it is to be neglected. Thus the voltage drop is independent from the characteristics of the line. For the 3-wire as well as for the 4-wire circuit it has to be considered that the circuit is not always led to the measuring element. The connection of the sensor to the connection head in the armature, the so called inner circuit, is often done in a 2-wire circuit. This results in the problems of a 2-wire circuit – even to a smaller extent.

INNER WIRES OF RESISTANCE THERMOMETERS

number of precision winding	circuit of inner wires			
	2-wire	3-wire	4-wire	2-wire with loop
Pt 100				
2 x Pt 100				
3 x Pt 100				

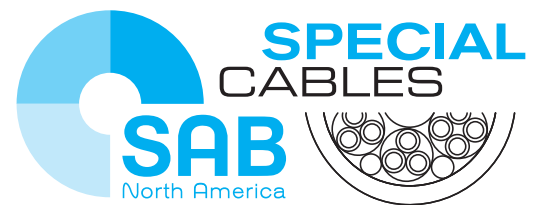

344 Kaplan Drive
Fairfield, NJ 07004
Toll Free: 866-722-2974
www.sabcable.com
info@sabcable.com